

INSTALLATION INSTRUCTIONS AND PARTS IDENTIFICATION SEPARATED COMBUSTION TUBULAR GAS FIRED DIRECT SPARK PROPELLER UNIT HEATERS

STPIM-4
J30-09054

ATTENTION: READ THIS MANUAL AND ALL LABELS ATTACHED TO THE UNIT CAREFULLY BEFORE ATTEMPTING TO INSTALL, OPERATE OR SERVICE THESE UNITS! CHECK UNIT DATA PLATE FOR TYPE OF GAS AND ELECTRICAL SPECIFICATIONS AND MAKE CERTAIN THAT THESE AGREE WITH THOSE AT THE POINT OF INSTALLATION. RECORD THE UNIT MODEL AND SERIAL No.(s) IN THE SPACE PROVIDED. RETAIN FOR FUTURE REFERENCE.

Unit No. _____ Serial No. _____

FOR YOUR SAFETY

The use and storage of gasoline or other flammable vapors and liquids in open containers in the vicinity of this appliance is hazardous.



FOR YOUR SAFETY

- If you smell gas:
1. Open windows.
 2. Don't touch electrical switches.
 3. Extinguish any open flame.
 4. Immediately contact your gas supplier.



▲ WARNING Improper installation, adjustment, alteration, service, or maintenance can cause property damage, injury, or death. Read the installation, operating, and maintenance instruction thoroughly before installing or servicing this equipment.

APPROVED FOR USE IN CALIFORNIA

▲ WARNING Install, operate, and maintain unit in accordance with the manufacturer's instructions to avoid exposure to fuel substances, or substances from incomplete combustion, which can cause death or serious illness. The state of California has determined that these substances may cause cancer, birth defects, or other reproductive harm.

INSTALLER'S RESPONSIBILITY

Installer Please Note: This equipment has been test fired and inspected. It has been shipped free from defects from our factory. However, shipment and installation problems such as loose wires, leaks, or loose fasteners may occur. **It is the installer's responsibility to inspect and correct any problem that may be found.**

RECEIVING INSTRUCTIONS

Inspect shipment immediately when received to determine if any damage has occurred to the unit during shipment. After the unit has been uncrated, check for any visible damage to the unit. If any damage is found, the consignee should sign the bill of lading indicating such damage and immediately file claim for damage with the transportation company.



MESTEK, INC.

260 NORTH ELM ST., WESTFIELD, MA 01085

TEL: (413) 568-9571 FAX: (413) 562-5311

www.mestek.com



TABLE OF CONTENTS

<p>SPECIFICATIONS</p> <p>Description..... 2</p> <p>Performance & Dimensional Data 4</p> <p>GENERAL SAFETY INFORMATION</p> <p>Installation Codes..... 2,3</p> <p>Special Precautions..... 2,3</p> <p>INSTALLATION</p> <p>Locating Units..... 5</p> <p>Combustion Air..... 5</p> <p>Heat Throw Data..... 6</p> <p>Clearances..... 7</p> <p>Suspension of Units..... 7</p> <p>Gas Piping..... 8</p>	<p>PIPE INSTALLATION..... 9</p> <p>ELECTRICAL CONNECTIONS..... 10-12</p> <p>VENTING..... 13-18</p> <p>OPERATION</p> <p>Explanation of Controls..... 19</p> <p>Gas Input Rate..... 20</p> <p>Main Burner Orifice Schedule..... 20</p> <p>TROUBLESHOOTING GUIDES..... 22-25</p> <p>MAINTENANCE..... 26</p> <p>WARRANTY..... 27</p> <p>IDENTIFICATION OF PARTS..... 28,29</p> <p>START-UP INSPECTION SHEET..... Back Cover</p>
---	---

NOTICE: It is the equipment owners responsibility to provide any scaffolding or other apparatus required to perform emergency service or annual/periodic maintenance to this equipment.

DESCRIPTION

The Separated Combustion Tubular Gas Fired Unit Heaters are a factory assembled, power vented, low static pressure type propeller fan unit heaters designed to be suspended within the space to be heated. THESE HEATERS ARE NOT TO BE CONNECTED

TO DUCTWORK. The designs are certified by ETL as providing a minimum of 83% thermal efficiency, and approved for use in California. Do not alter these units in any way. If you have any questions after reading this manual, contact the manufacturer.

Figure 1 - Separated Combustion Tubular Propeller Unit Heater

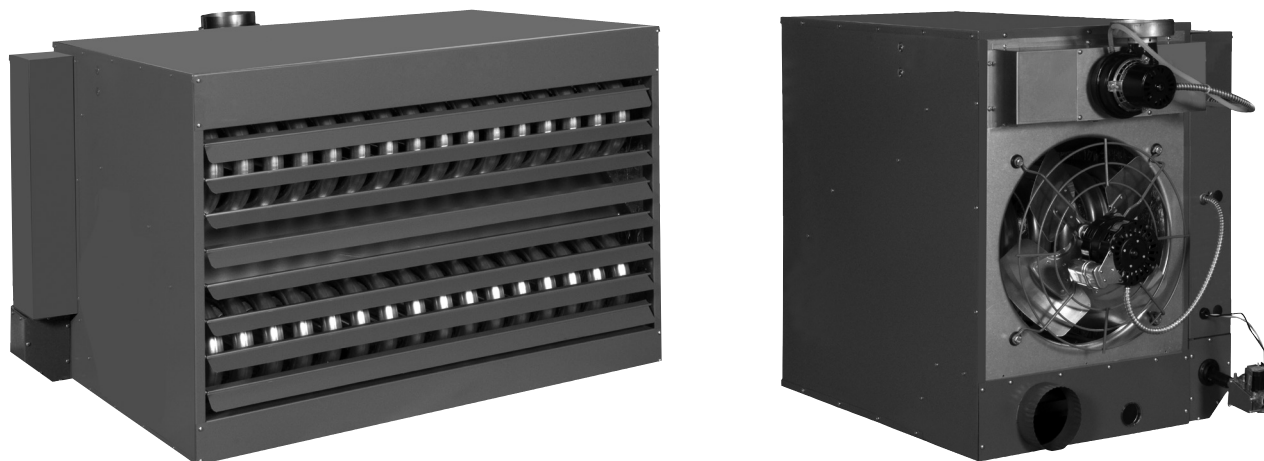

See Identification of Parts, Figures 8-15.

The following terms are used throughout this manual, in addition to the ETL requirements to bring attention to the presence of potential hazards, or to important information concerning the product:

▲ DANGER Indicates an imminently hazardous situation which, if not avoided, will result in death, serious injury, or substantial property damage.

▲ WARNING Indicates an imminently hazardous situation which, if not avoided, could result in death, serious injury, or substantial property damage.

▲ CAUTION Indicates an imminently hazardous situation which, if not avoided, may result in minor injury or property damage.

NOTICE: Used to notify of special instructions on installation, operation, or maintenance which are important to equipment but not related to personal injury.

GENERAL SAFETY INFORMATION

▲ WARNING Failure to comply with the general safety information may result in extensive property damage, severe personal injury, or death.

▲ WARNING This product must be installed by a licensed plumber or gas fitter when installed within the Commonwealth of Massachusetts.

Installation must be made in accordance with local codes, or in absence of local codes, with the latest edition of the ANSI Standard Z223.1 (N.F.P.A. No. 54) National Fuel Gas Code. All of the ANSI and NFPA Standards referred to in these installation instructions are those that were applicable at the time the design of this appliance was certified. The ANSI Standards are available from CSA Information Services, 1-800-463-6727. The NFPA Standards are available from the National Fire Protection Association, Batterymarch Park, Quincy, MA 02269. These unit heaters are designed for use in airplane hangars when installed in accordance with ANSI/NFPA No. 409, and in public garages when installed in accordance with NFPA No. 88A and NFPA No.88B.

If installed in Canada, the installation must conform with local building codes, or in the absence of local building codes, with CSA-B149.1 "Installation Codes for Natural Gas Burning Appliances and Equipment" or CSA-B149.2 "Installation Codes for Propane Gas Burning Appliances and Equipment." These unit heaters have been designed and certified to comply with CSA 2.6. Also see sections on installation in AIRCRAFT HANGARS and PUBLIC GARAGES.

▲ WARNING Do not alter the unit heater in any way or damage to the unit and/or severe personal injury or death may occur!

▲ WARNING Disconnect all power and gas supplies before installing or servicing the heater. If the power disconnect is out of sight, lock it in the open position and tag it to prevent unexpected application of power. Failure to do so could result in fatal electric shock, or severe personal injury.

▲ CAUTION Ensure that all power sources conform to the requirements of the unit heater, or damage to the unit will result!

Follow installation instructions CAREFULLY to avoid creating unsafe conditions. All wiring should be done and checked by a qualified electrician, using copper wire only. All gas connections should be made and leak-tested by a suitably qualified individual, per instructions in this manual. Also follow procedures listed on "Gas Equipment Start-Up Sheet" located in this manual.

Use only the fuel for which the heater is designed (see rating plate). Using LP gas in a heater that requires natural gas, or vice versa, will create risk of gas leaks, carbon monoxide poisoning, and explosion.

▲ WARNING Do not attempt to convert the heater for use with a fuel other than the one intended unless using an appropriate conversion kit provided by the manufacturer. Such conversion is dangerous, as it will create the risks previously listed.

Make certain that the power source conforms to the electrical requirements of the heater.

▲ WARNING Do not depend upon a thermostat or other switch as sole means of disconnecting power when installing or servicing heater. Always disconnect power at main circuit breaker as described above. Failure to do so could result in fatal electric shock.

Special attention must be given to any grounding information pertaining to this heater. To prevent the risk of electrocution, the heater must be securely and adequately grounded. This should be accomplished by connecting a ground conductor between the service panel and the heater. To ensure a proper ground, the grounding means must be tested by a qualified electrician.

Do not insert fingers or foreign objects into heater or its air moving device. Do not block or tamper with the heater in any manner while in operation, or just after it has been turned off, as some parts may be hot enough to cause injury.

This heater is intended for general heating applications ONLY. It must NOT be used in potentially dangerous locations such as flammable, explosive, chemical-laden, or wet atmospheres.

Do not attach ductwork to this product or use it as a makeup air heater. Such usage voids the warranty and will create unsafe operation.

In cases in which property damage may result from malfunction of the heater, a back-up system or temperature sensitive alarm should be used.

▲ CAUTION The open end of piping systems being purged shall not discharge into areas where there are sources of ignition or into confined spaces UNLESS precautions are taken as follows: (1) by ventilation of the space, (2) control of the purging rate, (3) elimination of all hazardous conditions. All precautions must be taken to perform this operation in a safe manner!

Unless otherwise specified, the following conversions may be used for calculating SI unit measurements:	
1 foot = 0.305 m	1000 BTU/cu. ft. = 37.5 MJ/m ³
1 inch = 25.4 mm	1000 BTU per hour = 0.293 kW
1 gallon = 3.785 L	1 inch water column = 0.249 kPa
1 pound = 0.453 kg	1 litre/second = CFM x 0.472
1 psig = 6.894 kPa	1 meter/second = FPM ÷ 196.8
1 cubic foot = 0.028m ³	

Table 1 - Performance and Dimensional Data - Separated Combustion Tubular Propeller Unit Heater

Unit Capacity (MBH)	100	125	150	175	200	250	300	350	400
PERFORMANCE DATA†									
Input - BTU/Hr.	100,000	125,000	150,000	175,000	200,000	250,000	300,000	350,000	400,000
(kW)	(29.3)	(36.6)	(43.9)	(51.2)	(58.6)	(73.2)	(87.8)	(102.5)	(117.1)
Output - BTU/Hr.	83,000	103,750	124,500	145,250	166,000	207,500	249,000	290,500	332,000
(kW)	(24.3)	(30.4)	(36.4)	(42.5)	(48.6)	(60.7)	(72.9)	(85.1)	(97.2)
Thermal Efficiency (%)	83								
Free Air Delivery - CFM	1,600	2,200	2,400	2,850	3,200	3,450	5,000	5,600	5,800
(cu. m/s)	(0.756)	(1.039)	(1.133)	(1.346)	(1.511)	(1.629)	(2.361)	(2.644)	(2.738)
Air Temperature Rise - Deg. F	47	42	47	46	47	54	45	47	51
(Deg. C)	(26)	(23)	(26)	(26)	(26)	(30)	(24)	(26)	(28)
Full Load Amps at 120V	6.4	6.9			8.0		11.3		13.5
MOTOR DATA: Motor HP (Qty)	1/10	1/4			1/3		1/4 (2)		1/3 (2)
Motor kW	(0.080)	(0.19)			(0.25)		(0.19)		(0.25)
Motor Type									
ODP**	SP	PSC			PSC		PSC		PSC
RPM	1,050	1,140			1,140		1,140		1,140
Amps @ 115V	4.2	4.7			5.8		9.4		11.6
DIMENSIONAL DATA - inches (mm)									
"A" Overall Height to Top of Flue			33-3/4 (857)					34 (864)	
"B" Jacket Width of Unit		20-3/4 (527)			32-3/4 (831)			50-3/4 (1289)	
"C" Width to CL Flue		13-3/8 (340)			19-3/8 (492)			28-3/8 (721)	
"D" Depth to Rear of Housing			11 (279)					12-1/4 (311)	
"E" Hanging Distance Width		18-5/8 (473)			30-5/8 (778)			48-5/8 (1235)	
"F" Discharge Opening Width		18-3/4 (476)			30-3/4 (781)			48-3/4 (1238)	
"G" Depth to CL Flue			4-3/4 (121)					5-1/8 (130)	
"L" Overall Unit Width		25-1/4 (641)			37-1/4 (946)			55-1/4 (1403)	
"M" Flue Size Diameter* - in (mm)			5 (127)					6 (152)	
Gas Inlet, Natural Gas - in					1/2			3/4	
Gas Inlet, LP Gas - in					1/2			3/4	
Approximate Unit Weight - lb (kg)	135 (61)	147 (67)	157 (71)	194 (88)	204 (93)	214 (97)	311 (141)	325 (147)	339 (154)
Approximate Ship Weight - lb (kg)	175 (79)	187 (85)	197 (89)	244 (111)	254 (115)	264 (120)	371 (168)	385 (175)	399 (181)

† Ratings shown are for unit installations at elevations between 0 and 2,000 ft (0 to 610m). For unit installations in U.S.A. above 2,000 ft. (610m), the unit input must be field derated 4% for each 1,000 ft. (305m) above sea level; refer to local codes, or in absence of local codes, refer to the latest edition of the National Fuel Gas Code, ANSI Standard Z223.1 (N.F.P.A. No. 54).

For installations in Canada, any reference to deration at altitudes in excess of 2,000 ft. (610m) are to be ignored. At altitudes of 2,000 ft. to 4,500 ft. (610 to 1372m), the unit must be field derated to 90% of the normal altitude rating, and be so marked in accordance with the ETL certification. See Table 6A for field deration information.

* Flue collar is factory supplied with unit; to be field installed per included instructions.

** LEGEND: SP = SHADED POLE PSC = PERMANENT SPLIT CAPACITOR ODP = OPEN DRIP PROOF

Figure 2 - Dimensional Drawing – Separated Combustion Tubular Propeller Unit Heater

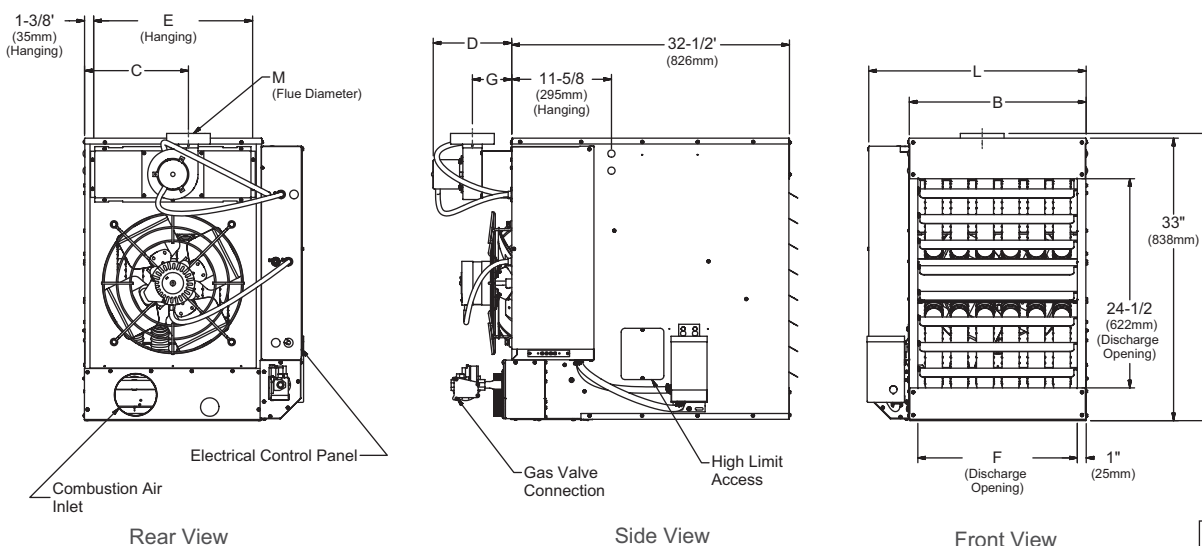

D9067B

INSTALLATION

▲ WARNING Do not install unit heaters in corrosive or flammable atmospheres! Premature failure of, or severe damage to the unit will result!

▲ WARNING Avoid locations where extreme drafts can affect burner operation. Unit heaters must not be installed in locations where air for combustion would contain chlorinated, halogenated or acidic vapors. If located in such an environment, premature failure of the unit will occur!

Since the unit is equipped with an automatic gas ignition system, the unit heater must be installed such that the gas ignition control system is not directly exposed to water spray, rain or dripping water.

NOTICE: Location of unit heaters is related directly to the selection of sizes. Basic rules are as follows:

MOUNTING HEIGHT: Unit Heaters equipped with standard fan guards must be installed at a minimum of 8 ft. (2.4m) above the floor, measured to the bottom of the unit. At heights above 8 ft. (2.4m), less efficient air distribution will result. **If a unit is to be mounted below 8 ft. (2.4m) from the floor, an OSHA approved fan guard is required on the unit.**

AIRCRAFT HANGARS: Unit Heaters must be installed in aircraft hangars as follows: In aircraft hangars, unit heaters must be at least 10 ft. (3.0m) above the upper surface of wings or engine enclosures of the highest aircraft to be stored in the hangar, and 8 ft. (2.4m) above the floor in shops, offices and other sections of the hangar where aircraft are not stored or housed. Refer to current ANSI/NFPA No. 409, Aircraft Hangars. In Canada, installation is suitable in aircraft hangars when acceptable to the enforcing authorities.

PUBLIC GARAGES: In repair garages, unit heaters must be located at least 8 ft. (2.4m) above the floor. Refer to the latest edition of NFPA 88B, Repair Garages.

PARKING STRUCTURES: In parking structures, unit heaters must be installed so that the burner flames are located a minimum of 18 in. (457mm) above the floor or protected by a partition not less than 18 in. (457mm) high. However, any unit heater mounted in a parking structure less than 8 ft. (2.4m) above the floor must be equipped with an OSHA approved fan guard. Refer to the latest edition of NFPA 88A, Parking structures.

In Canada, installation must be in accordance to the latest edition of CSA B149 "Installation Codes for Gas Burning Appliances and Equipment."

AIR DISTRIBUTION: Direct air towards areas of maximum heat loss. When multiple heaters are involved, circulation of air around the perimeter is recommended where heated air flows along exposed walls. Satisfactory results can also be obtained where multiple heaters are located toward the center of the area with heated air directed toward the outside walls. Be careful to avoid all obstacles and obstructions which could impede the warm air distribution patterns.

Unit heaters should not be installed to maintain low temperatures and/or freeze protection of buildings. A minimum of 50°F (10°C) thermostat setting must be maintained. If unit heaters are operated to maintain lower than 50°F (10°C), hot flue gases are cooled inside the heat exchanger to a point where water vapor (a flue gas by-product) condenses onto the heat exchanger walls. The result is a mildly corrosive acid that prematurely corrodes the aluminized heat exchanger and can actually drip water down from the unit heater onto floor surface. Additional unit heaters should be installed if a minimum 50°F (10°C) thermostat setting cannot be maintained.

NOTICE: Unit Heater sizing should be based on heat loss calculations where the unit heater output equals or exceeds heat loss.

NOTICE: Unit should be installed in an area where the entering air does not exceed 104°F. Temperatures above 104°F will cause the propeller motor to trip on its thermal overload protection, requiring a cool down period before the motor can reset.

INSTALLATION (continued)

Table 2 - Heat Throw Data

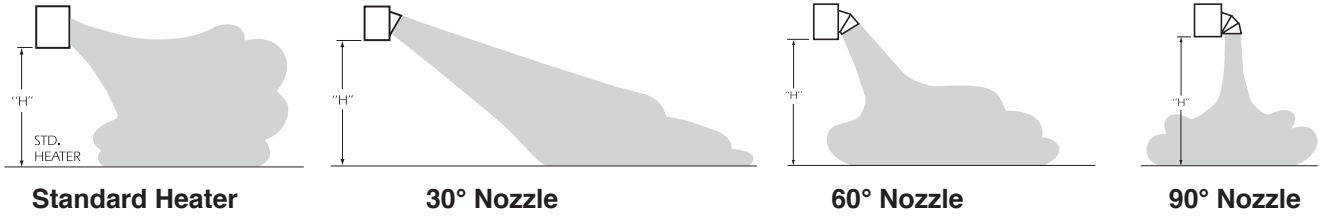

Degree of Nozzle	Distance From Floor to Bottom of Unit "H" - ft (m)	UNIT SIZE BTU/Hr								
		100,000	125,000	150,000	175,000	200,000	250,000	300,000	350,000	400,000
		Approximate Distance of Heat Throw - Feet (Meters)								
None	8 (2.4)	60 (18.3)	65 (19.8)	70 (21.3)	75 (22.9)	80 (24.4)	90 (27.4)	105 (32.0)	110 (33.5)	120 (36.6)
	10 (3.0)	54 (16.5)	56 (17.1)	60 (18.3)	64 (19.5)	68 (20.7)	78 (23.8)	90 (27.4)	95 (29.0)	100 (30.5)
	12 (3.7)	44 (13.4)	46 (14.0)	49 (14.9)	57 (17.4)	61 (18.6)	68 (20.7)	80 (24.4)	84 (25.6)	90 (27.4)
	15 (4.6)	NR	NR	45 (13.7)	49 (14.9)	52 (15.8)	60 (18.3)	70 (21.3)	74 (22.6)	80 (24.4)
	20 (6.1)	NR	NR	NR	NR	46 (14.0)	54 (16.5)	63 (19.2)	66 (20.1)	70 (21.3)
30°	8 (2.4)	65 (19.8)	70 (21.3)	75 (22.9)	80 (24.4)	85 (25.9)	95 (29.0)	115 (35.1)	120 (36.6)	125 (38.1)
	10 (3.0)	57 (17.4)	60 (18.3)	64 (19.5)	68 (20.7)	72 (21.9)	86 (26.2)	99 (30.2)	105 (32.0)	110 (33.5)
	12 (3.7)	50 (15.2)	54 (16.5)	57 (17.4)	60 (18.3)	64 (19.5)	77 (23.5)	88 (26.8)	94 (28.7)	100 (30.5)
	15 (4.6)	NR	45 (13.7)	48 (14.6)	50 (15.2)	53 (16.2)	64 (19.5)	74 (22.6)	79 (24.1)	84 (25.6)
	20 (6.1)	NR	NR	NR	44 (13.4)	47 (14.3)	58 (17.7)	66 (20.1)	71 (21.6)	75 (22.9)
60°	8 (2.4)	75 (22.9)	80 (24.4)	85 (25.9)	90 (27.4)	95 (29.0)	110 (33.5)	125 (38.1)	130 (39.6)	138 (42.1)
	10 (3.0)	65 (19.8)	70 (21.3)	75 (22.9)	79 (24.1)	83 (25.3)	95 (29.0)	109 (33.2)	115 (35.1)	120 (36.6)
	12 (3.7)	60 (18.3)	64 (19.5)	68 (20.7)	72 (21.9)	76 (23.2)	84 (25.6)	100 (30.5)	103 (31.4)	108 (32.9)
	15 (4.6)	50 (15.2)	54 (16.5)	56 (17.1)	61 (18.6)	65 (19.8)	71 (21.6)	85 (25.9)	88 (26.8)	94 (28.7)
	20 (6.1)	NR	49 (14.9)	52 (15.8)	55 (16.8)	59 (18.0)	65 (19.8)	77 (23.5)	81 (24.7)	85 (25.9)
90°*	15 (4.6)	30 x 25 (9.1)	35 x 30 (10.7)	40 x 35 (12.2)	45 x 40 (13.7)	50 x 40 (15.2)	60 x 45 (18.3)	70 x 45 (21.3)	80 x 50 (24.4)	100 x 50 (30.5)
	20 (6.1)	NR	NR	NR	NR	40 x 35 (12.2)	56 x 40 (17.1)	65 x 40 (19.8)	70 x 45 (21.3)	80 x 45 (24.4)
	25 (7.6)	NR	NR	NR	NR	NR	50 x 35 (15.2)	60 x 35 (18.3)	65 x 40 (19.8)	75 x 40 (22.9)
	30 (9.1)	NR	NR	NR	NR	NR	NR	55 x 35 (16.8)	60 x 35 (18.3)	65 x 40 (19.8)

* It is not recommended to mount a unit with a 90° nozzle under 10 feet.

- Notes:**
1. All throw data figures are approximations. Allowances should be made for optimum performance, altitude, etc.
 2. NR - Units not recommended at these mounting heights.
 3. 30°, 60° and 90° nozzles are shipped unassembled.

INSTALLATION (continued)

CLEARANCES: Each Gas Unit Heater shall be located with respect to building construction and other equipment so as to permit access to the Unit Heater. Clearance between vertical walls and the vertical sides of the Unit Heater shall be no less than 6 in. (152mm). To ensure access to the control box, a minimum of 18 in. (457mm) is required for the control box side. A minimum clearance of 6 in. (152mm) must be maintained between the top of the Unit Heater and the ceiling. The bottom of the Unit Heater must be no less than 12 in. (305mm) from any combustible. The distance between rear of unit and vertical wall should be no less than 18 in. to maintain inlet air flow. The distance between the flue collector and any combustible must be no less than 6 in. (152mm). Also see VENTING section.

NOTICE: Increasing the clearance distances may be necessary if there is a possibility of distortion or discoloration of adjacent materials.

▲ WARNING Make certain that the lifting methods used to lift the heater and the method of suspension used in the field installation of the heater are capable of uniformly supporting the weight of the heater at all times. Failure to heed this warning may result in property damage or personal injury!

▲ WARNING Make sure that the structure to which the unit heater is to be mounted is capable of safely supporting its weight. Under no circumstances must the gas lines, the venting system or the electrical conduit be used to support the heater; or should any other objects (i.e. ladder, person) lean against the heater gas lines, venting system or the electrical conduit for support. Failure to heed these warnings may result in property damage, personal injury, or death.

▲ CAUTION Unit Heaters must be hung level from side to side and from front to back, see Figure 3A and 3B. Failure to do so will result in poor performance and/or premature failure of the unit.

▲ WARNING Ensure that all hardware used in the suspension of each unit heater is more than adequate for the job. Failure to do so may result in extensive property damage, severe personal injury, or death!

Refer to Figures 3A and 3B for suspension of units.

Figure 3A - Heater Mounting*

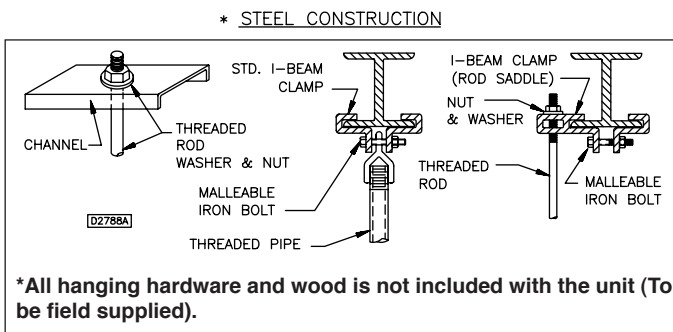

Note: Threaded rod is 3/8".

Figure 3B - Heater Suspension

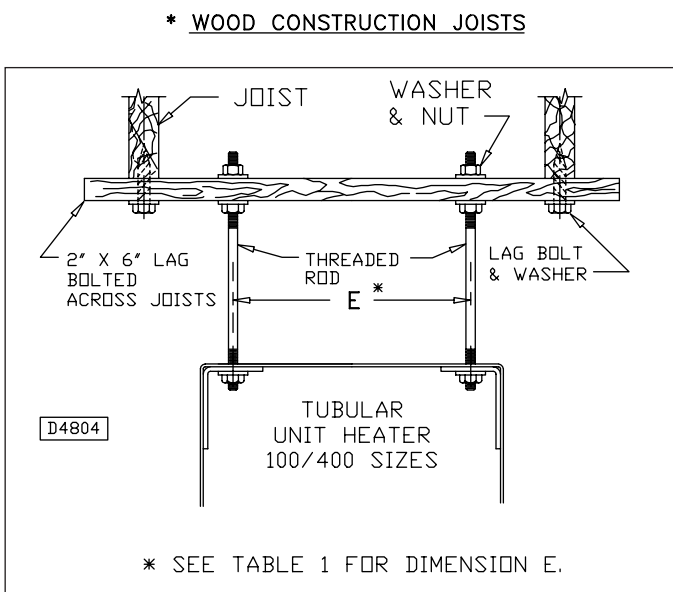

Note: Threaded rod is 3/8".

INSTALLATION (continued)

GAS PIPING

▲ WARNING To avoid damage or possible personal injury, do not connect gas piping to this unit until a supply line pressure/leak test has been completed. Connecting the unit before completing the pressure/leak test may damage the unit gas valve and result in a fire hazard.

▲ WARNING Do not rely on a shut-off valve to isolate the unit while conducting gas pressure/leak tests. These valves may not be completely shut off, exposing the gas valve to excessive pressure and damage.

PIPE SIZING

To provide adequate gas pressure to the gas unit heater, size the gas piping as follows:

- Find the cu. ft./hr. by using the following formula:

$$\text{Cu. ft./hr.} = \frac{\text{Input BTU/Hr.}}{1000}$$

- Refer to Table 3. Match "Length of Pipe in Feet" with appropriate "Gas Input - Cu. Ft./Hr." figure. This figure can then be matched to the pipe size at the top of the column.

Example:

It is determined that a 67 ft. (20.4m) run of gas pipe is required to connect a 200 MBTU gas unit heater to a 1,000 BTU/cu ft. (0.29kW) natural gas supply.

$$\frac{200,000 \text{ BTU/Hr}}{1,000 \text{ BTU/cu. ft.}} = 200 \text{ Cu. ft./hr.}$$

Using Table 3, a 1 inch pipe is needed.

NOTE: See General Safety Information section for English/Metric unit conversion factors.

NOTICE: If more than one unit heater is to be served by the same piping arrangement, the total cu. ft./hr. input and length of pipe must be considered.

NOTICE: If the gas unit heater is to be fired with LP gas, consult your local LP gas dealer for pipe size information.

NOTICE: HEATER INSTALLATION FOR USE WITH PROPANE (BOTTLED) GAS MUST BE MADE BY A QUALIFIED L.P. GAS DEALER OR INSTALLER. HE/SHE WILL INSURE THAT PROPER JOINT COMPOUNDS ARE USED FOR MAKING PIPE CONNECTIONS; THAT AIR IS PURGED FROM LINES; THAT A THOROUGH TEST IS MADE FOR LEAKS BEFORE OPERATING THE HEATER; AND THAT IT IS PROPERLY CONNECTED TO THE PROPANE GAS SUPPLY SYSTEM.

Before any connection is made to the existing line supplying other gas appliances, contact the local gas company to make sure that the existing line is of adequate size to handle the combined load.

Table 3 - Gas Pipe Size

Maximum Capacity of Pipe in Cubic Feet of Gas per Hour (Cubic Meters per Hour) for Gas Pressures of 0.5 psig (3.5 kPa) or Less, and a Pressure Drop of 0.5 Inch Water Column (124.4 Pa)
(Based on a 0.60 Specific Gravity Gas)

Nominal Iron	Internal Dia.	Length of Pipe, Feet (meters)													
		10 (3.0)	20 (6.1)	30 (9.1)	40 (12.2)	50 (15.2)	60 (18.3)	70 (21.3)	80 (24.4)	90 (27.4)	100 (30.5)	125 (38.1)	150 (45.7)	175 (53.3)	200 (61.0)
1/2	0.622	175 (4.96)	120 (3.40)	97 (2.75)	82 (2.32)	73 (2.07)	66 (1.87)	61 (1.73)	57 (1.61)	53 (1.50)	50 (1.42)	44 (1.25)	40 (1.13)	37 (1.05)	35 (0.99)
3/4	0.824	360 (10.2)	250 (7.08)	200 (5.66)	170 (4.81)	151 (4.28)	138 (3.91)	125 (3.54)	118 (3.34)	110 (3.11)	103 (2.92)	93 (2.63)	84 (2.38)	77 (2.18)	72 (2.04)
1	1.049	680 (19.3)	465 (13.2)	375 (10.6)	320 (9.06)	285 (8.07)	260 (7.36)	240 (6.80)	220 (6.23)	205 (5.80)	195 (5.52)	175 (4.96)	160 (4.53)	145 (4.11)	135 (3.82)
1 1/4	1.380	1400 (39.6)	950 (26.9)	770 (21.8)	660 (18.7)	580 (16.4)	530 (15.0)	490 (13.9)	460 (13.0)	430 (12.2)	400 (11.3)	360 (10.2)	325 (9.20)	300 (8.50)	280 (7.93)
1 1/2	1.610	2100 (59.5)	1460 (41.3)	1180 (33.4)	990 (28.0)	900 (25.5)	810 (22.9)	750 (21.2)	690 (19.5)	650 (18.4)	620 (17.6)	550 (15.6)	500 (14.2)	460 (13.0)	430 (12.2)
2	2.067	3950 (112)	2750 (77.9)	2200 (62.3)	1900 (53.8)	1680 (47.6)	1520 (43.0)	1400 (39.6)	1300 (36.8)	1220 (34.5)	1150 (32.6)	1020 (28.9)	950 (26.9)	850 (24.1)	800 (22.7)
2 1/2	2.469	6300 (178)	4350 (123)	3520 (99.7)	3000 (85.0)	2650 (75.0)	2400 (68.0)	2250 (63.7)	2050 (58.0)	1950 (55.2)	1850 (52.4)	1650 (46.7)	1500 (42.5)	1370 (38.8)	1280 (36.2)
3	3.068	11000 (311)	7700 (218)	6250 (177)	5300 (150)	4750 (135)	4300 (122)	3900 (110)	3700 (105)	3450 (97.7)	3250 (92.0)	2950 (83.5)	2650 (75.0)	2450 (69.4)	2280 (64.6)
4	4.026	23000 (651)	15800 (447)	12800 (362)	10900 (309)	9700 (275)	8800 (249)	8100 (229)	7500 (212)	7200 (204)	6700 (190)	6000 (170)	5500 (156)	5000 (142)	4600 (130)

1. Determine the required Cu. Ft./Hr. by dividing the input by 1000. For SI/Metric measurements: Convert BTU/Hr. to kilowatts. Multiply the units inputs (kW) by 0.0965 to determine Cu. Meters./Hr. 2. FOR NATURAL GAS: Select pipe size directly from the table. 3. FOR PROPANE GAS: Multiply the Cu. Ft./Hr. value by 0.633; then, use the table. 4. Refer to the metric conversion factors listed in the General Safety section for SI Unit measurement conversions.

PIPE INSTALLATION

1. Install the gas piping in accordance with applicable local codes.
2. Check gas supply pressure. Each unit heater must be connected to a manifold pressure and a gas supply capable of supplying its full rated capacity as specified in Table 4. A field LP tank regulator must be used to limit the supply pressure to a maximum of 14 in. W.C. (3.5 kPa). All piping should be sized in accordance with the latest edition of ANSI Standard Z223.1 (NFPA 54), National Fuel Gas Code; in Canada, according to CSA B149. See Tables 1 & 3 for correct gas piping size. If gas pressure is excessive on natural gas applications, install a pressure regulating valve in the line upstream from the main shutoff valve.
3. Adequately support the piping to prevent strain on the gas manifold and controls.
4. To prevent the mixing of moisture with gas, run the take-off piping from the top, or side, of the main.
5. Standard Unit Heaters, optional two-stage units are supplied with a combination valve which includes:
 - a. Manual "A" valve
 - b. Manual "B" valve
 - c. Solenoid valve
 - d. Pressure regulator
 Pipe directly into the combination valve (see Figure 4).
6. Gas valve has a pressure test post requiring a 3/32 in. hex head wrench to read gas supply and manifold pressures. Open 1/4 turn counterclockwise to read, turn clockwise to close and reseal. A 5/16 in. ID hose fits the pressure post.
7. Provide a drip leg in the gas piping near the gas unit heater. A ground joint union and a manual gas shutoff valve should be installed ahead of the unit heater controls to permit servicing. The manual shutoff valve must be located external to the jacket (See Figure 4).
8. Make certain that all connections have been adequately doped and tightened.

▲ CAUTION Do not over tighten the inlet gas piping into the valve. This may cause stresses that will crack the valve!

NOTICE: Use pipe joint sealant resistant to the action of liquefied petroleum gases regardless of gas conducted.

▲ WARNING Check all pipe joints for leakage using a soap solution or other approved method. Never use an open flame or severe personal injury or death may occur!

Figure 4 - Pipe Installation, Standard Controls

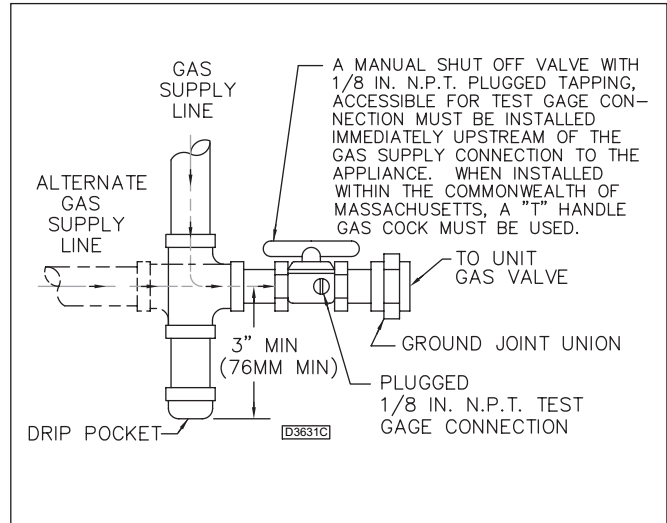

▲ WARNING Never use an open flame to detect gas leaks. Explosive conditions may exist which may result in personal injury or death!

The appliance and its individual shutoff valve must be disconnected from the gas supply piping system during any pressure testing of that system in excess of 1/2 psig (3.5 kPa).

The appliance must be isolated from the gas supply piping system by closing its individual manual shutoff valve during any pressure testing of the gas supply piping system at test pressures equal to or less than 1/2 psig (3.5 kPa).

Table 4 - Gas Piping Requirements

SINGLE STAGE GAS PIPING REQUIREMENTS*		
Gas Type	Natural Gas	Propane (LP) Gas
Manifold Pressure	3.5 in. W.C. (0.9 kPa)	10.0 in. W.C. (2.5 kPa)
Supply Inlet Pressure	14.0 in. W.C. Max. (3.5 kPa)	14.0 in. W.C. Max. (3.5 kPa)
	5.0 in. W.C. Min. (1.2 kPa)	11.0 in. W.C. Min. (2.7 kPa)

*For single stage application only at normal altitudes.

ELECTRICAL CONNECTIONS



▲ WARNING

HAZARDOUS VOLTAGE!
DISCONNECT ALL ELECTRIC POWER INCLUDING REMOTE DISCONNECTS BEFORE SERVICING. Failure to disconnect power before servicing can cause severe personal injury or death.

Standard units are shipped for use on 115 volt, 60 hertz, single phase electric power. The motor name-plate and electrical rating of the transformer should be checked before energizing the unit heater electrical system. All external wiring must conform to the latest edition of ANSI/NFPA No. 70, United States National Electrical Code, and applicable local codes; in Canada, to the Canadian Electrical Code, Part 1, CSA Standard C22.1.

▲ CAUTION Do not use any tools (i.e. screwdriver, pliers, etc.) across terminals to check for power. Use a voltmeter.

It is recommended that the electrical power supply to each unit heater be provided by a separate, fused, and permanently live electrical circuit. A disconnect switch of suitable electrical rating should be located as close to the gas valve and controls as possible. Each unit heater must be electrically grounded in accordance with the latest edition of the United States National Electrical Code, ANSI/NFPA No. 70, or CSA Standard C22.1. Refer to Figures 5a, 5b, 5c, 5d and 5e.

THERMOSTAT WIRING AND LOCATION:

NOTICE: The thermostat must be mounted on a vertical, vibration-free surface, free from air currents, and in accordance with the furnished instructions.

Mount the thermostat approximately 5 ft. (1.5m) above the floor, in an area where it will be exposed to a free circulation of average temperature air. Always refer to the thermostat instructions, as well as our unit wiring diagram, and wire accordingly. Avoid mounting the thermostat in the following locations:

1. Cold Areas - Outside walls or areas where drafts may affect the operation of the control.
2. Hot Areas - Areas where the sun's rays, radiation, or warm air currents may affect the operation of the control.
3. Dead Areas - Areas where the air cannot circulate freely, such as behind doors or in corners.

Figure 5a - Low-voltage Thermostat Wiring Single Stage

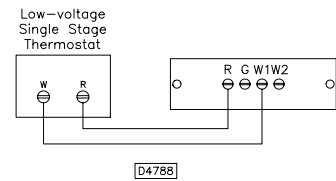

Figure 5b - Low-voltage Thermostat Wiring Two Stage

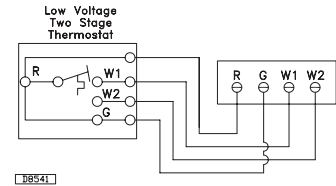
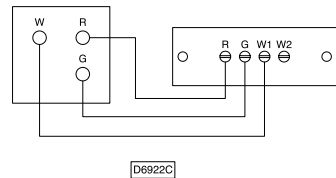

Figure 5c - Low-voltage T834H or T834N (or equivalent) Thermostat Wiring Single Stage



NOTICE: The start-up fan delay should not exceed 30 seconds from a cold start.

IMPORTANT: For all wiring connections, refer to the wiring diagram shipped with your unit (either affixed to the side jacket or enclosed in the installation instructions envelope). Should any original wire supplied with the heater have to be replaced, it must be replaced with wiring material having a temperature rating of at least 105°C.

Should any high limit wires have to be replaced, they must be replaced with wiring material having a temperature rating of 200°C minimum.

ELECTRICAL CONNECTIONS (continued)

Figure 5d - Separated Combustion Tubular Unit Sizes 100-300 Equipped with Natural Gas and Propane (LP) Gas

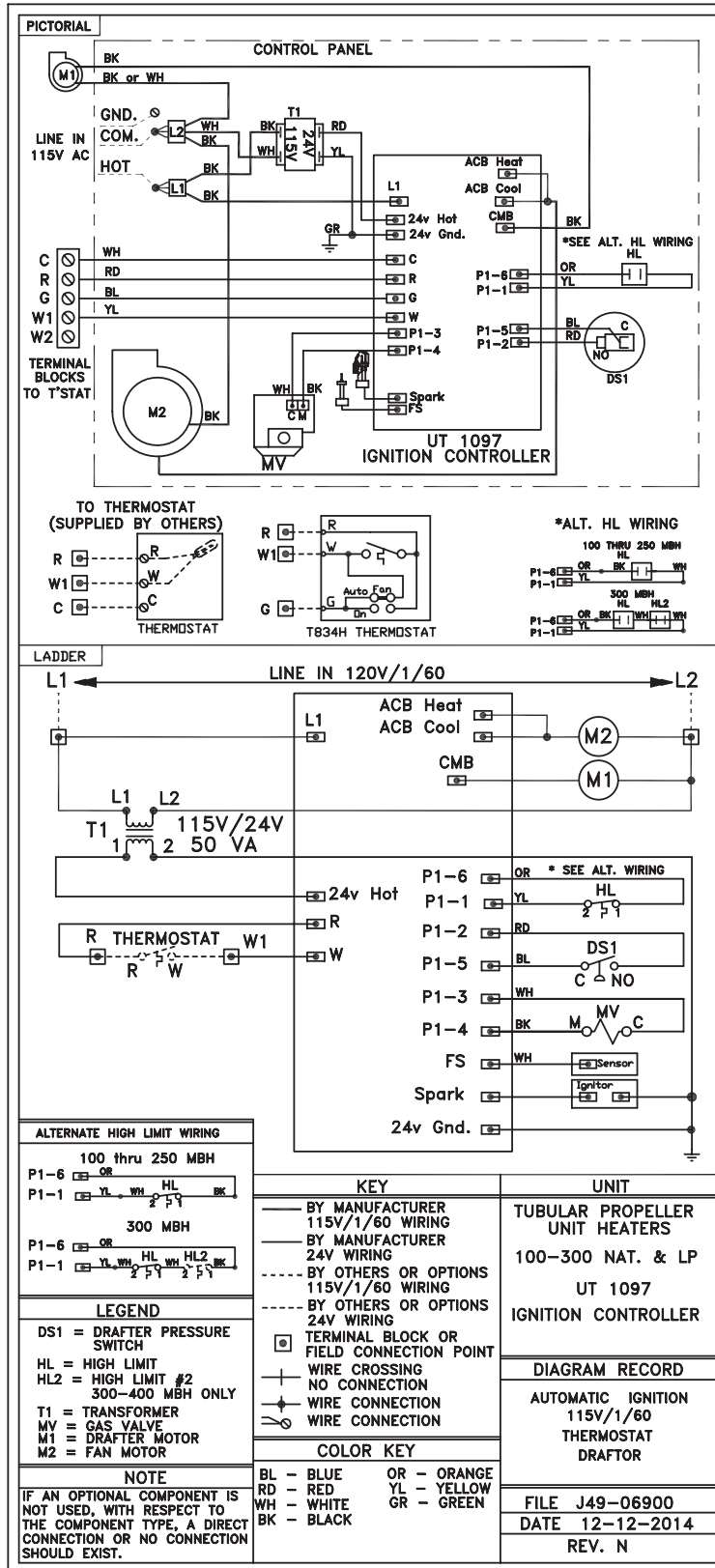

ELECTRICAL CONNECTIONS (continued)

Figure 5e - Separated Combustion Tubular Unit Sizes 100-300 with Optional 2-Stage Ignition

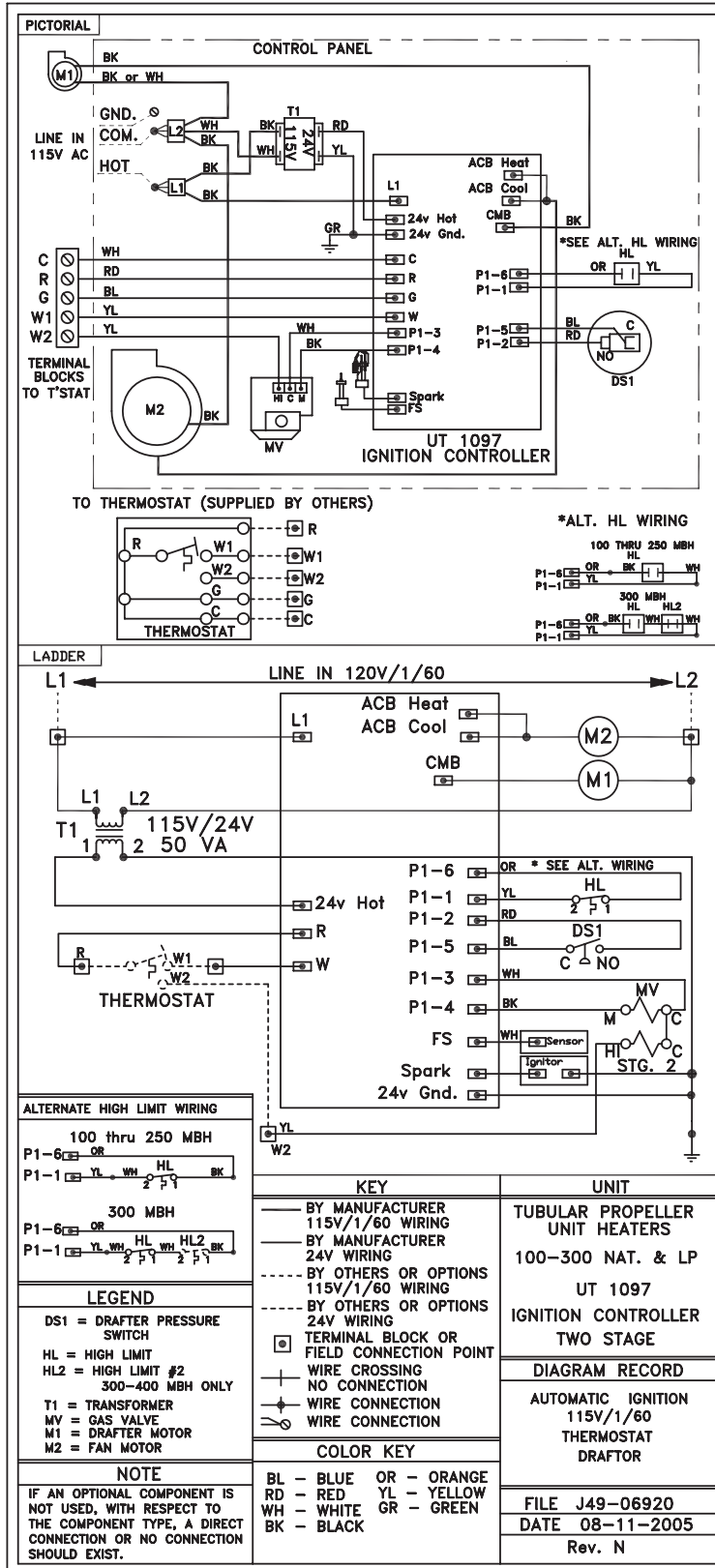

ELECTRICAL CONNECTIONS (continued)

Figure 5f - Separated Combustion Tubular Unit Sizes 350-400 Equipped with Natural Gas and Propane (LP) Gas

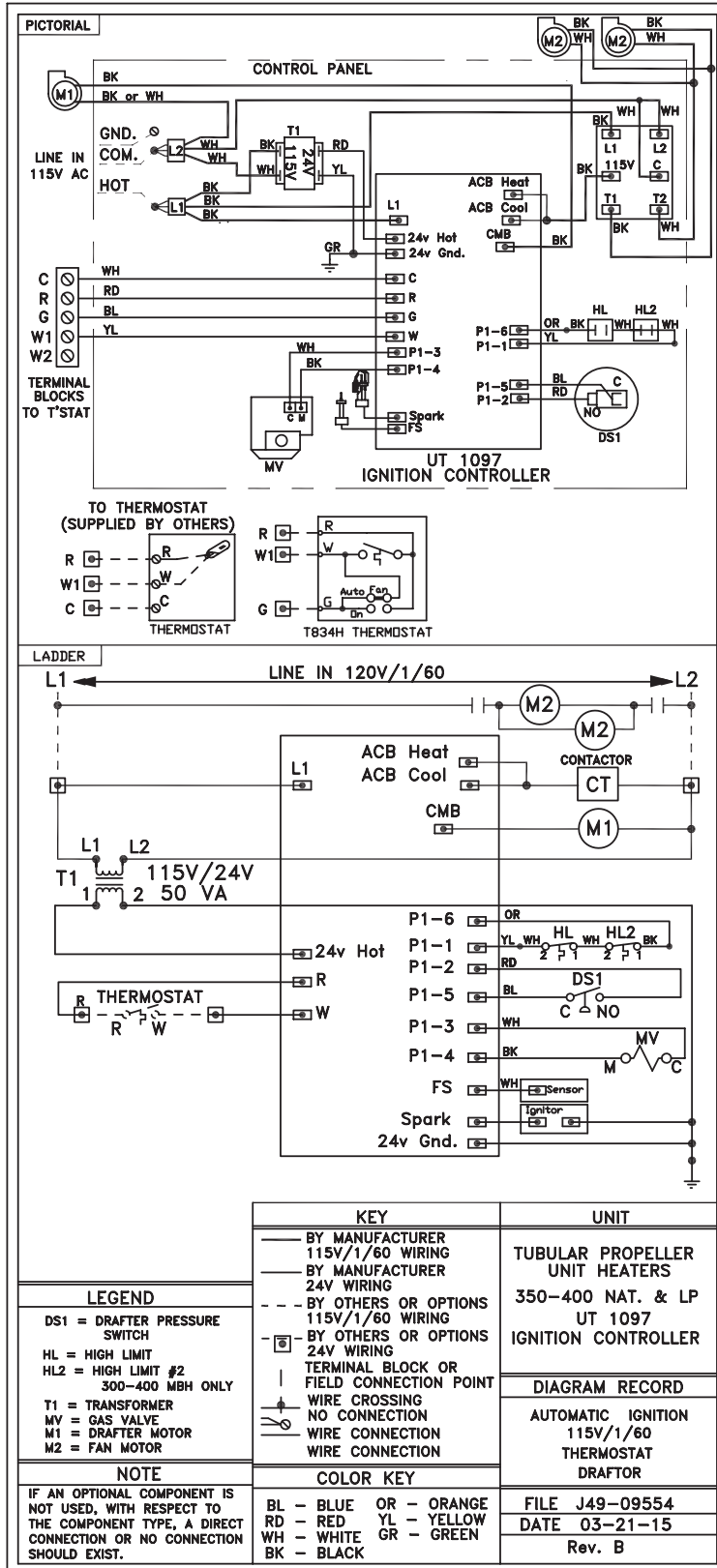

ELECTRICAL CONNECTIONS (continued)

Figure 5g - Separated Combustion Tubular Unit Sizes 350-400 with Optional 2-Stage Ignition

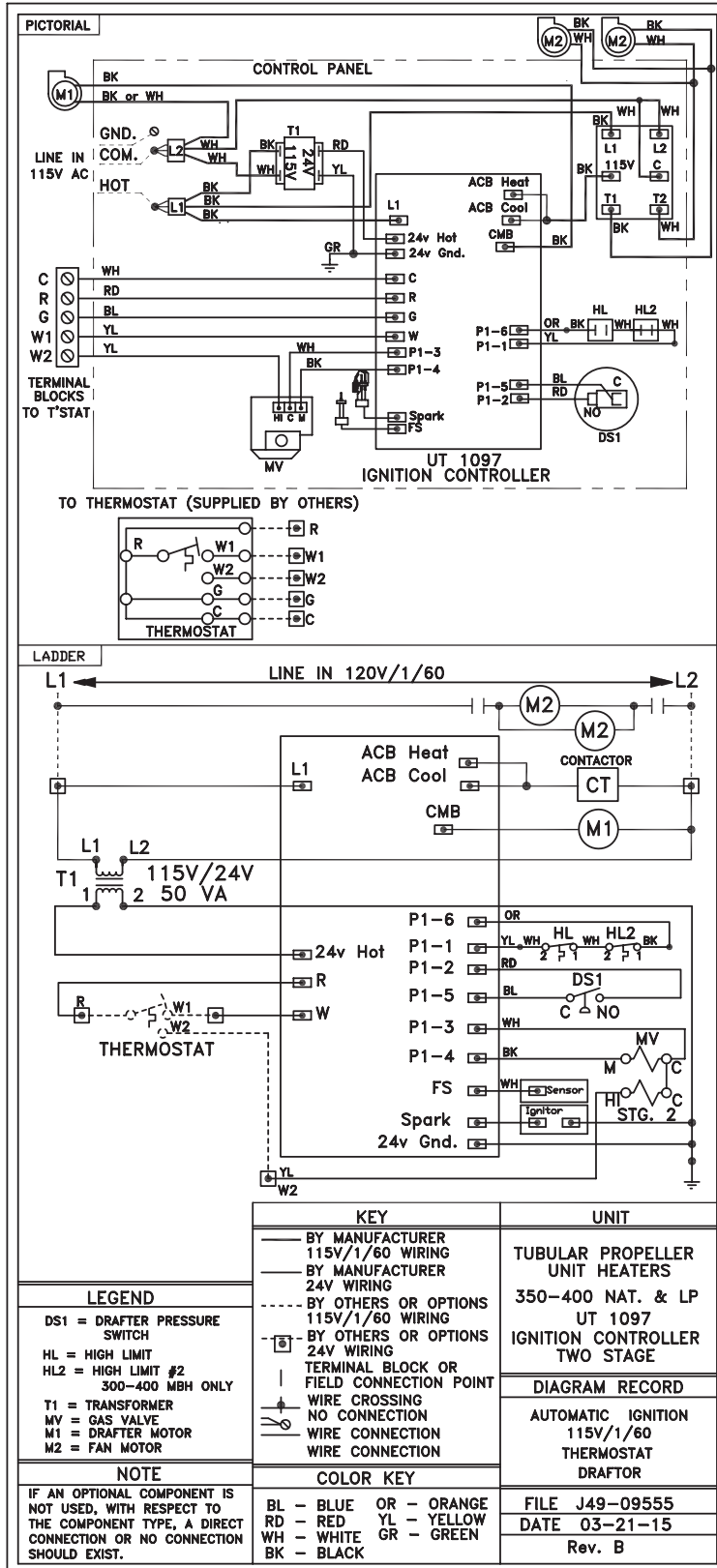

VENTING

ANSI now organizes vented appliances into four categories.

Venting Categories

	Non-Condensing	Condensing
Negative Vent Pressure	I	II
Positive Vent Pressure	III	IV

Category I

Includes non-condensing appliances with negative vent pressure, like the traditional atmospheric unit heater.

Category II

Groups condensing appliances with negative vent pressure.

Category III

Appliances are non-condensing and operate with a positive vent pressure.

Category IV

Covers condensing appliances with positive vent pressure.

NOTICE: Category II and IV do not apply to equipment specified within this manual.

All unit heaters must be vented! All Venting installations shall be in accordance with the latest edition of Part 7, Venting of Equipment of the National Fuel Gas Code, ANSI Z223.1 (NFPA 54), or applicable provisions of local building codes. Refer to page 15 for Canadian installations. Refer to Figures 6A, 6B, 7A, 7B, 8A and 8B.

▲ WARNING CARBON MONOXIDE! Your venting system must not be blocked by any snow, snow drifts, or any foreign matter. Inspect your venting system to ensure adequate ventilation exists at all times! Failure to heed these warnings could result in Carbon Monoxide Poisoning (symptoms include grogginess, lethargy, inappropriate tiredness, or flu-like symptoms).

Do not damper or add heat recovery devices to the flue piping. Failure to open such a damper prior to operating gas unit will result in the spillage of flue gas into the occupied space.

VERTICALLY VENTED UNIT HEATERS (CATEGORY I)

Observe the following precautions when venting the unit:

- Use flue pipe of the same size as the flue connections on the gas unit heater (See Table #1). All heaters should be vented with double wall or single wall vent, a factory built chimney, or a lined brick and mortar chimney that has been constructed in accordance with the National Building Code. Type B vent should only be used for vertical rise portions of a Category I vent pipe system. Type B vent should not be used for horizontal runs of vent pipe.
- Provide as long a vertical run of flue pipe at the gas unit heater as possible. A minimum of 5 ft. (1.5m) of vertical flue is required. The top of the vent pipe should extend at least 2 ft. (0.61m) above the highest point on the roof within 10 feet (3.05m) of the termination. Install a weather cap over the vent opening. Consideration should be made for anticipated snow depth.
- Slope horizontal runs upward from the gas unit heater at least 1/4 in. per foot (21mm/m) minimum. Horizontal runs should not exceed 75% of the vertical height of the vent pipe, or chimney, above the flue pipe connection, up to a maximum length of 10 ft. (3m). Horizontal portions of the venting system shall be supported at minimum intervals of 4 ft. (1.2m). In Canada, support at minimum intervals of 3 ft. (1m).
- Use as few elbows as possible. The vent pipe equivalent length must not exceed 50 feet (15.2m). Equivalent length is the total length of straight sections PLUS 10 feet (3.05m) for each 90° elbow and 4 feet (1.22m) for each 45° elbow.
- Avoid running vent pipe through unheated indoor spaces.
- When this cannot be avoided, insulate the pipe to prevent condensation of moisture on the walls of the pipe.
- Do not damper the flue piping. Failure to open such a damper prior to operating the gas unit heater will result in the spillage of flue gas into the occupied space.
- Avoid installing units in areas under negative pressure due to large exhaust fans or air conditioning. When required, a flue vent fan should be installed in accordance with the instructions included with the fan.
- Vent connectors serving Category I and Category II heaters shall not be connected into any portion of mechanical draft systems operating under positive pressure.

VENTING (continued)

HORIZONTALLY VENTED UNIT HEATERS (CATEGORY III)

Horizontal venting arrangements are designed to be used with single wall vent pipe. Horizontal venting arrangements must terminate external to the building using UL 1738 Listed and approved single wall or double wall vent. For installations in Canada, use corrosion resistant and gas-tight, listed vent pipe conforming with local building codes, or in the absence of local building codes, with current CSA-B149.1, Installation Codes for Natural Gas Burning Appliances and Equipment or CSA-B149.2, Installation Codes for Propane Gas Burning Appliances and Equipment.

▲ WARNING Do not use Type B (double wall) vent internally within the building on horizontally vented power vented units! This can result in death, serious injury or substantial property damage.

Single wall and double wall venting components which are UL 1738 Listed and approved for Category III positive pressure venting systems MUST be used.

A Breidert Type L, Fields Starkap, or equivalent vent cap must be supplied by the customer for each power vented unit. The vent pipe diameter MUST be as specified in Table 1 (“D” Dia. Flue Opening). All unit sizes are factory equipped with the required flue size collar; attach in place (if not mounted to outlet); refer to included vent collar instruction sheet for additional requirements.

Table 5

Vent Systems Termination Clearance Requirements		
Structure/Object	Minimum Clearance for Termination Locations	
	USA	CANADA
Door, window, or gravity vent inlet; combustion air inlet for other appliances	9 in. for 10,000 to 50,000 BTU/Hr input; 12 in. for input exceeding 50,000 BTU/Hr.	9 in. (230mm) for 10,000 to 50,000 BTU/Hr input; 12 in. (305mm) for input exceeding 50,000 BTU/Hr.
Forced air inlet within 10 ft.	3 ft. above	6 ft. (1.8m)
Adjoining Building or parapet	10 ft.	10 ft. (3.04m)
Adjacent public walkways	7 ft. above grade	7 ft. (2.1m) above grade
Electric, gas meters & regulators	4 ft. horizontal	3 ft. (0.9m) horizontally from meter/regulator assembly. 6 ft. (1.8m), any direction, from a gas service regulator vent outlet
Above grade level*	1 ft.	1 ft. (0.3m)

*Minimum above maximum snow depth, or per local code, whichever is greater.

The vent terminal must be at least 12 in. (305mm) from the exterior of the wall that it passes through to prevent degradation of the building material by flue gases.

Through the wall vent for these appliances shall NOT terminate over public walkways, or over an area where the condensate or vapor could create a nuisance or hazard or could be detrimental to the operation of regulators, relief valves, or other equipment.

The vent pipe equivalent length must not exceed 50 ft. (15.2m). Equivalent length is the total length of straight sections PLUS 10 ft. (3.05m) for each 90° elbow and 4 ft. (1.22m) for each 45° elbow.

Maintain clearance between the vent pipe and combustible materials according to vent pipe manufacturer’s instructions

Seal all vent pipe joints and seams to prevent leakage. Use General Electric RTV-108, Dow-Corning RTV-732 silicone sealant or equivalent sealant with a temperature rating of 500°F; or 3M #425 aluminum foil tape (or equivalent). The vent air system must be installed to prevent collection of condensate. Pitch horizontal pipes downward 1/4 inch per foot (21mm per meter) toward the outlet for condensate drainage.

Horizontal portions of the venting systems shall be supported at maximum intervals of 4 ft. (1.2m) to prevent sagging (in Canada, support at 3 ft. (1m) maximum intervals).

Insulate single wall vent pipe exposed to cold air or running through unheated areas.

Each unit must have an individual vent pipe and vent terminal! Each unit MUST NOT be connected to other vent systems or to a chimney.

VENTING (continued) VERTICALLY VENTED UNIT HEATERS (CATEGORY III)

Vertical venting arrangements are designed to be used with single wall vent pipe. Vertical venting arrangements must terminate external to the building using UL 1738 listed and approved single wall or double wall vent. For installations in Canada, use corrosion resistant and gas-tight, listed vent pipe conforming with local building codes, or in the absence of local building codes, with current CSA-B149.1, Installation Codes for Natural Gas Burning Appliances and Equipment or CSA-B149.2, Installation Codes for Propane Gas Burning Appliances and Equipment.

▲ WARNING Do not use Type B (double wall) vent internally within the building on vertically vented power vented units! This can result in death, serious injury, or substantial property damage.

Single wall and double wall venting components which are UL 1738 Listed and approved for Category III positive pressure venting systems MUST be used.

A Breidert Type L, Fields Starkap, or equivalent vent cap must be supplied by the customer for each power vented unit. The vent pipe diameter MUST be as specified in Table 1. All unit sizes are factory equipped with the required flue size collar; attach in place (if not mounted to outlet); refer to included vent collar instruction sheet for additional requirements.

The top of the vent pipe should extend at least 2 feet (0.61m) above the highest point on the roof within 10 feet (3.05m) of the termination. Consideration should be made for anticipated snow depth. Install the vent cap over the vent opening. Slope horizontal runs upward from the gas unit heater at least 1/4-inch per foot (21mm/m) minimum. Horizontal portions of the venting system shall be supported at minimum intervals of 4 feet (1.2m) (in Canada, support at 3 foot (1m) minimum intervals).

Vent system terminations for these appliances shall NOT terminate in an area where the condensate or vapor could create a nuisance or hazard or could be detrimental to the operation of regulators, relief valves, or other equipment. See Table 5 for additional vent termination clearance requirements.

The vent pipe equivalent length must not exceed 50' (15.2m). Equivalent length is the total length of straight sections PLUS 10' (3.05m) for each 90° elbow and 4' (1.22m) for each 45° elbow.

Maintain clearance between the vent pipe and combustible materials according to vent pipe manufacturer's instructions.

Seal all vent pipe joints and seams to prevent leakage. Use General Electric RTV-108, Dow-Corning RTV-732 silicone sealant or equivalent sealant with a temperature rating of 500°F; or 3M #425 aluminum foil tape (or equivalent). The vent air system must be installed to prevent collection of condensate. Slope horizontal runs upward from the gas unit at least 1/4" per foot (21mm per meter) minimum.

Horizontal portions of the venting systems shall be supported at maximum intervals of 4' (1.2m) to prevent sagging (in Canada, support at 3' (1m) maximum intervals).

Insulate single wall vent pipe exposed to cold air or running through unheated indoor areas.

Each unit must have an individual vent pipe and vent terminal! Each unit MUST NOT be connected to other vent systems or to a chimney.

VENTING (continued)

NOTICE: Combustion and exhaust venting instructions below describe two-pipe venting. If venting concentrically, a Combustion Air Inlet Kit is required and instructions included in the kit should be followed.

COMBUSTION AIR VENTING AND PIPING

▲ WARNING Never operate unit heaters without combustion air and flue gas piping in place or severe personal injury or death may occur!

▲ WARNING CARBON MONOXIDE!
Your venting system must not be blocked by any snow, snow drifts, or any foreign matter. Inspect your venting system to ensure adequate ventilation exists at all times! Failure to heed these warnings could result in Carbon Monoxide Poisoning (symptoms include grogginess, lethargy, inappropriate tiredness, or flu-like symptoms).

1. The combustion air system installation must be in accordance with the current National Fuel Gas Code-NFPA 54 or ANSI Z223.1 National Fuel Gas Code. In Canada, installation must be in accordance with CSA-B149.1 "Installation Code for Natural Gas Burning Appliances and Equipment" and CSA-B149.2 "Installation Code for Propane Burning Appliances and Equipment".
2. A Breidert Type L or Fields inlet cap, furnished by the customer, must be installed at the termination point of the combustion air system, Figures 6A & 7A.
3. Each unit heater MUST have it's own combustion air system. It MUST NOT be connected to other air intake systems.
4. Use UL 1738 Listed single wall pipe for the vent system. For installations in Canada, use corrosion resistant and gas-tight, listed vent pipe conforming with local building codes, or in the absence of local building codes, with current CSA-B149.1, Installation Codes for Natural Gas Burning Appliances and Equipment or CSA-B149.2, Installation Codes for Propane Gas Burning Equipment.

▲ WARNING Never use pipe of a diameter other than that specified in Table 1, page 4! Never use PVC, ABS or any other non-metallic pipe for venting! To do so may result in serious damage to the unit and or severe personal injury or death!

5. Long runs of single wall combustion air piping passing through an unheated space may require insulating if condensation becomes noticeable.
6. The combustion air system must be installed to prevent collection of condensate. Pitch horizontal pipes downward 1/4 in. per foot (21mm/m) toward the inlet cap to facilitate drainage. Vertical combustion air pipes should be piped as depicted in Figure 6A.

7. The equivalent length of the vent system must not be less than 5 ft. and must not exceed 50 ft. (15.2m). Equivalent length equals the total length of straight pipe plus 10 ft. (3.05m) for each 90° elbow and 4 ft. (1.22m) for each 45° elbow.

NOTICE: For optimum performance keep the combustion air system as straight as possible.

8. Each slip joint must be secured with at least three corrosion resistant screws. Two full turns of 3M #425 Aluminum Foil Tape or its equivalent must then be used to seal each joint. General Electric RTV-108, Dow-Corning RTV-732 or an equivalent may be used instead of the tape.
9. For horizontal combustion air systems longer than 5 ft. (1.5m), the system must be supported from overhead building structures at 3 ft. (1m) intervals.

EXHAUST VENTING

▲ WARNING Never operate unit heaters without combustion air and flue gas piping in place or severe personal injury or death may occur!

1. Vent system installation must be in accordance with the current National Fuel Gas Code-NFPA 54 or ANSI Z223.1 National Fuel Gas Code. In Canada installation must be in accordance with CSA-B149.1 "Installation Code for Natural Gas Burning Appliances and Equipment" and CSA-B149.2. "Installation Code for Propane Burning Appliances and Equipment".
2. A Breidert Type L or Fields vent cap, furnished by the customer, must be installed at the termination point of the vent system, Figures 6A & 7A.
3. Each unit heater MUST have it's own vent system. It MUST NOT be connected to other vent systems or to a chimney.
4. Use UL 1738 Listed single wall pipe. For installations in Canada, use corrosion resistant and gas-tight, listed vent pipe conforming with local building codes, or in the absence of local building codes, with current CSA-B149.1, Installation Codes for Natural Gas Burning Appliances and Equipment or CSA-B149.2, Installation Codes for Propane Gas Burning Appliances and Equipment.

▲ WARNING Never use pipe of a diameter other than that specified in Table 1, page 4! Never use PVC, ABS or any other non-metallic pipe for venting! To do so may result in serious damage to the unit and or severe personal injury or death!

VENTING (continued)

5. Any run of single wall vent pipe passing through an unheated space must be insulated with an insulation suitable to 550°F (288°C).
6. The vent system must be installed to prevent collection of condensate. Pitch horizontal pipes downward 1/4 in. per foot (21mm/m) toward the vent cap to facilitate drainage. Vertical vent pipes should be piped as depicted in Figure 6A.
7. The equivalent length of the vent system must not be less than 5 ft. (1.5m) and must not exceed 50 ft. (15.2m). Equivalent length equals the total length of straight pipe plus 10 ft. (3.05m) for each 90° elbow and 4 ft. (1.22m) for each 45° elbow.
8. Each slip joint must be secured with at least three corrosion resistant screws. Two full turns of 3M #425 Aluminum Foil tape or its equivalent must then be used to seal each joint. General Electric RTV-108, Dow-Corning RTV-732 or an equivalent may be used instead of the tape.
9. For horizontal vent systems longer than 5 ft. (1.5m), the system must be supported from overhead building structures at 3 ft. (1m) intervals.
10. The exhaust vent system must remain at a minimum distance of 6 in. (152mm) from all combustible materials. Any part of the vent system that passes through a combustible material must be properly insulated.

NOTICE: Increasing the clearance distances may be necessary if there is a possibility of distortion or discoloration of adjacent materials.

For a VERTICAL vent pipe section that passes through a floor or roof, an opening 4 in. (102mm) greater in diameter is required (See Table 1, dimension "M"). The opening must be insulated and flashed in accordance with applicable installation codes. See Figure 7A.

A HORIZONTAL section of an exhaust vent system that passes through a combustible wall must be constructed and insulated as shown in Figure 7B.

Figure 6A - Vertical Intake/Vent Installation

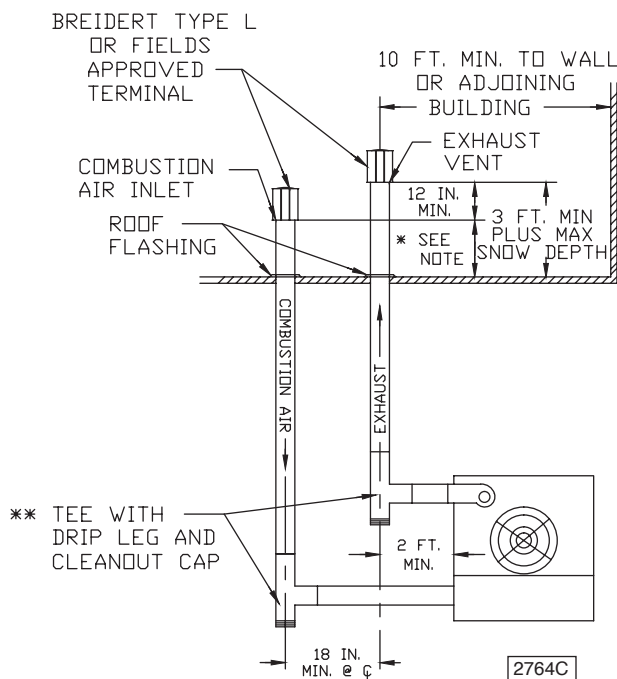

* 2 ft. minimum plus maximum snow depth for area.

** If excessive condensation develops, a drip leg with a condensate drain may be required. Insulating the pipes may eliminate the problem.

Figure 6B - Horizontal Intake/Vent Locations

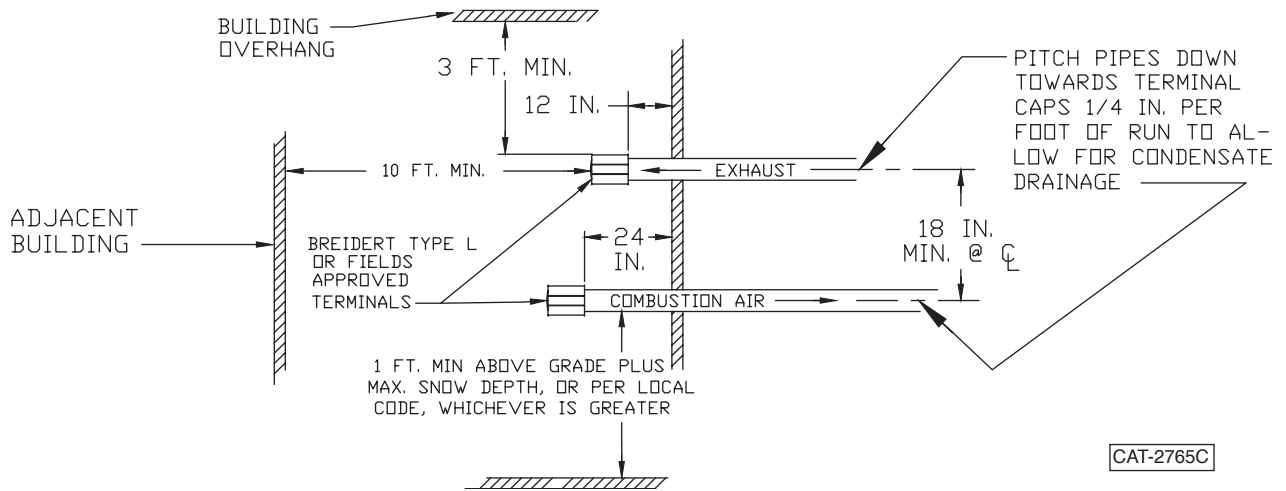

Figure 7A - Vertical Vent Installation

HORIZONTAL ARRANGEMENT
SINGLE WALL VENT SYSTEM TO SINGLE WALL TERMINATION

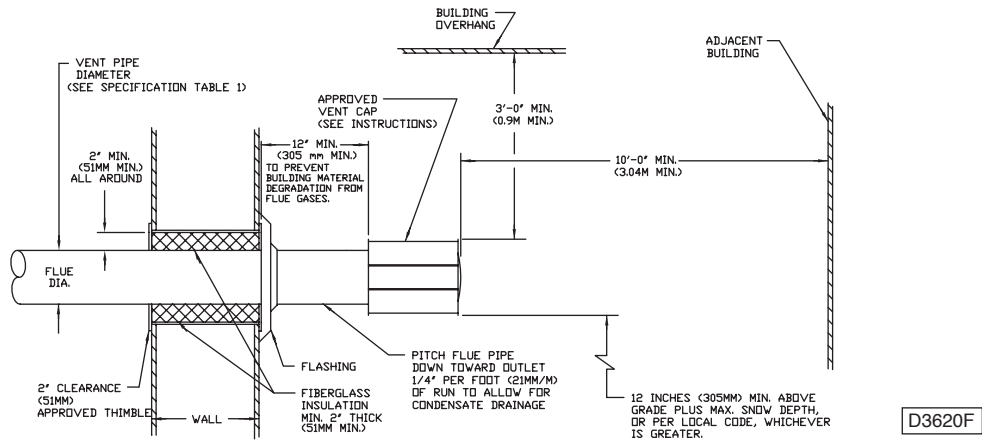

Figure 7B - Horizontal Vent Installation

VERTICAL ARRANGEMENT
SINGLE WALL VENT SYSTEM TO SINGLE WALL TERMINATION

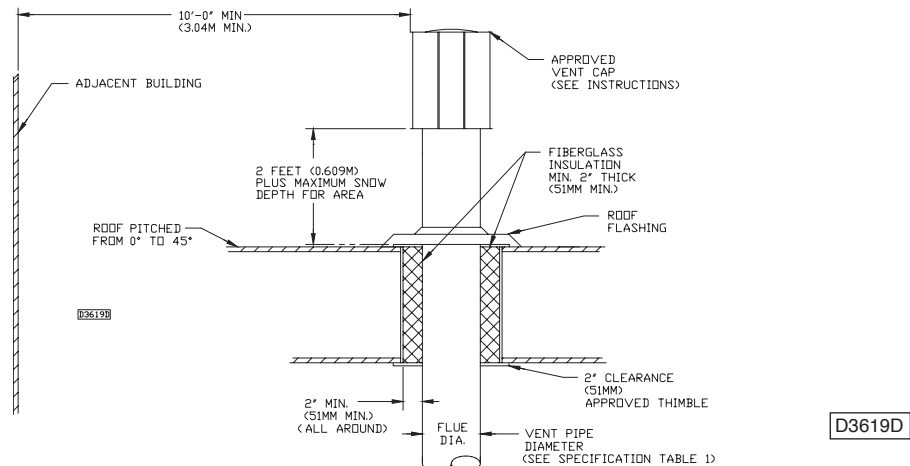

Figure 8A - Vertical Venting Requirements

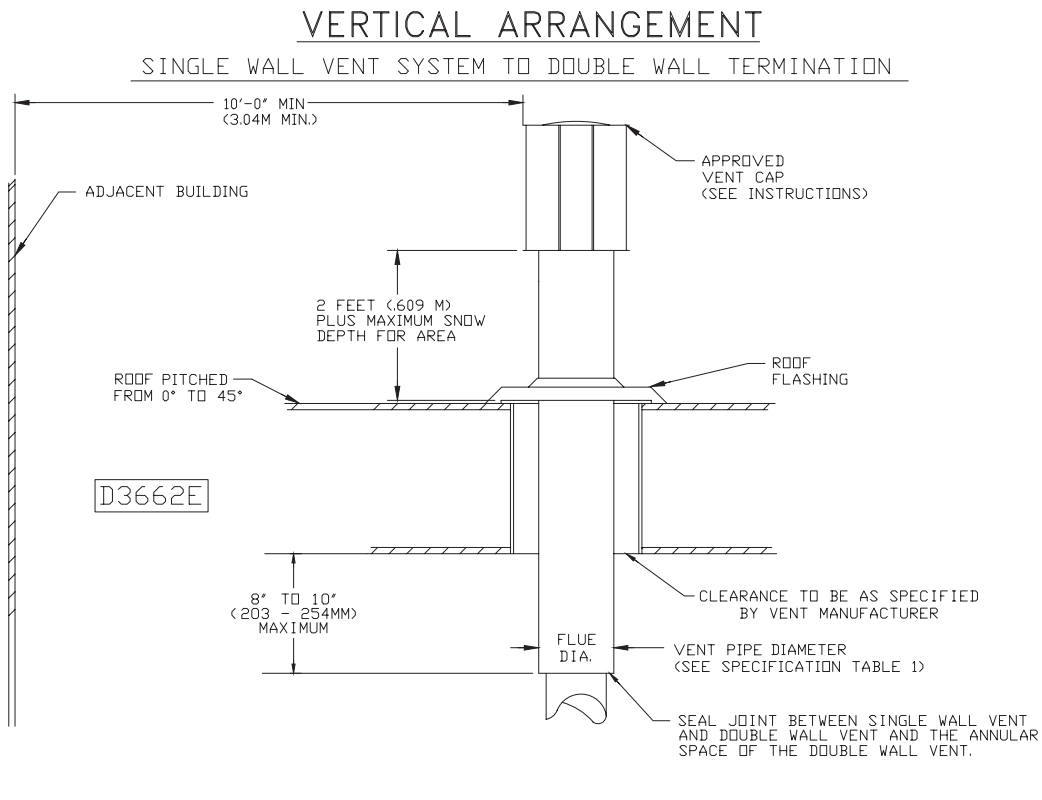
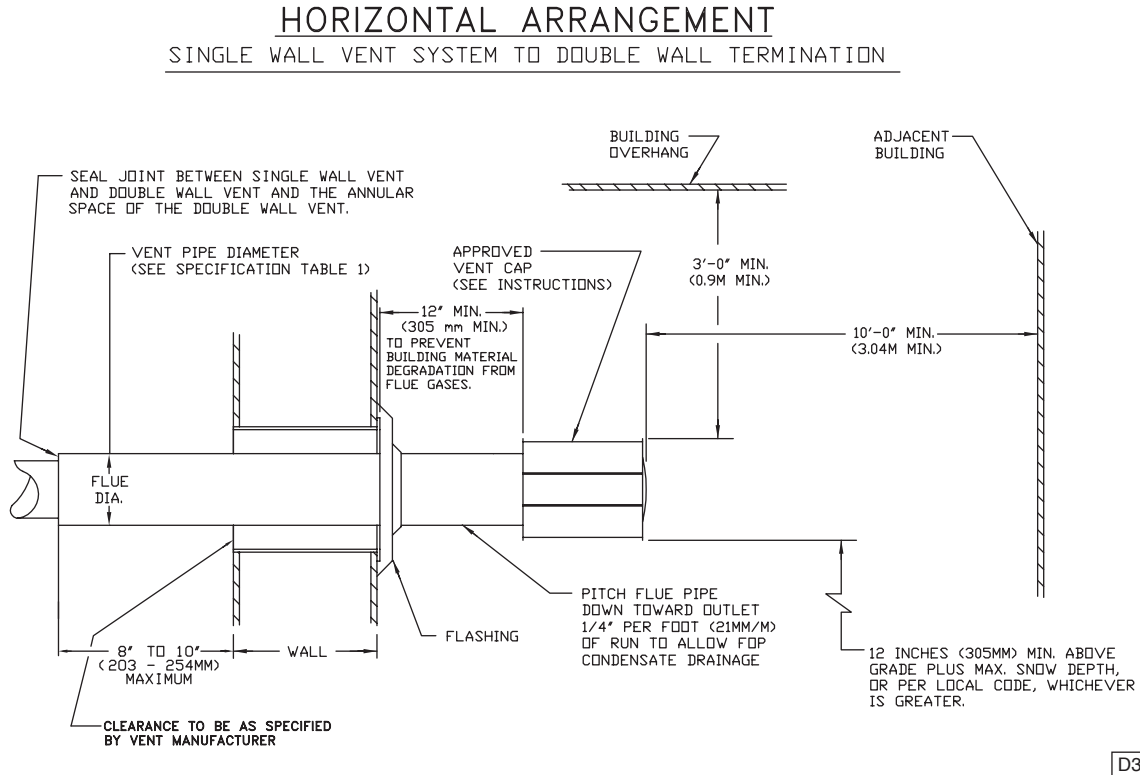

Figure 8B - Horizontal Venting Requirements



ADDITIONAL REQUIREMENT FOR CANADIAN INSTALLATIONS

REFER TO SPECIFICATION TABLE AND INSTALLATION MANUAL FOR PROPER USAGE.

- * The following instructions apply to Canadian installations in addition to installation and operating instructions.
1. Installation must conform with local building codes, or in the absence of local codes, with current CSA B149.1, Installation Codes for Natural Gas Burning Appliances and Equipment, or CSA B149.2, Installation Codes for Propane Gas Burning Appliances and Equipment.
 2. Any reference to U. S. standards or codes in these instructions are to be ignored, and the applicable Canadian standards or codes applied.

OPERATION

SEPARATED COMBUSTION TUBULAR PROPELLER UNITS

DIRECT SPARK IGNITION

EXPLANATION OF CONTROLS:

1. The unit heater is equipped with a power vent system that consists of a power venter motor and blower, pressure switch, and sealed flue collector in place of the conventional draft diverter.
2. The power venter motor is energized by the room thermostat through the integrated control board when a demand for heat is sensed. The pressure switch measures the flow through the vent system and energizes the direct spark ignition system beginning the pre-purge timing when the flow is correct.

▲ WARNING The pressure switch **MUST NOT** be bypassed. The unit **MUST NOT** be fired unless the power venter is operating. An unsafe condition could result.

3. The direct ignition system consists of an ignition control module and a gas valve. When the pre-purge period ends, the spark ignition system is energized, and the gas valve opens to supply gas to the burners. When the thermostat is satisfied, the vent system is de-energized and the valve closes to stop the flow of gas to the unit.
4. The limit switch interrupts the flow of electric current to the control board, interrupting the flow of gas to the gas valve if the unit heater becomes overheated.
5. Once the thermostat is satisfied, or the limit switch interrupts the flow of electric current to the control board, the unit will begin a post-purge period. When the post-purge period ends, the power venter motor is de-energized.
6. The fan operation is delayed 30 seconds once the thermostat is closed, and continues operation for 30 seconds after the thermostat opens.

7. The wall thermostat, supplied optionally, is a temperature sensitive switch that operates the vent and ignition system to control the temperature of the space being heated. The thermostat must be mounted on a vertical, vibration-free surface free from air currents and in accordance with the furnished instructions (also refer to Electrical Section).

START-UP (Also refer to lighting instruction plate equipped on the unit)

1. Open the manual gas valve in the gas supply line to the unit heater. Loosen the union in the gas line to purge it of air. Tighten the union and check for leaks.

▲ WARNING Never use an open flame to detect gas leaks. Explosive conditions may exist which could result in personal injury or death.

2. Open the manual valve on the unit heater.
3. Turn ON the electrical power.
4. The unit should be under the control of the thermostat. Turn the thermostat to the highest point and determine that the power venter motor starts and the burners ignite. Turn the thermostat to the lowest point and determine that the power venter motor shuts off and the burners are extinguished.
5. Turn the thermostat to the desired position.
6. See Gas Input Rate and Adjustments sections.

SHUT DOWN

1. Turn the valve selector lever to the "OFF" position.
2. Turn off the electricity.
3. To relight, follow "start-up" instructions.

See Figures 9-15 for parts/identification.

NOTICE: The start-up fan delay must not exceed 30 seconds from a cold start.

Figure 9
Direct Spark Ignition
System, Bottom View

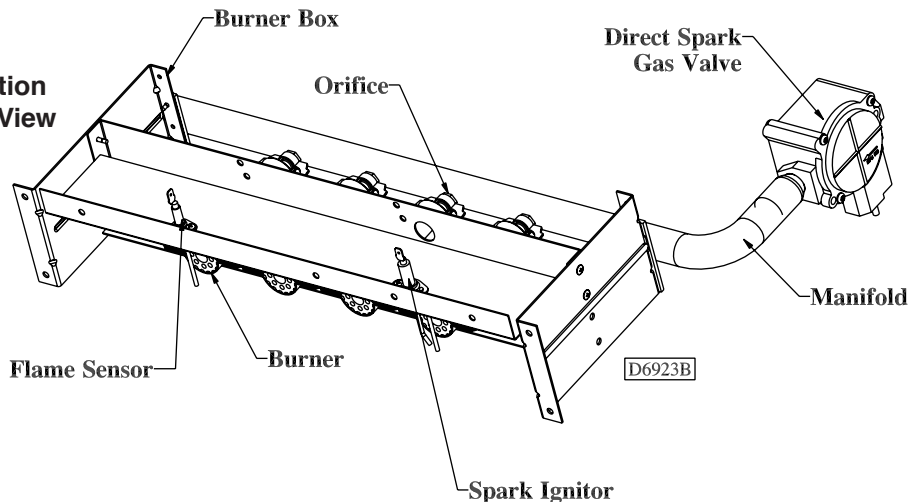

OPERATION (continued)

PRIMARY AIR SHUTTER ADJUSTMENT

Primary air adjustment is made at the factory. No field adjustments are necessary.

GAS INPUT RATE

Check the gas input rate as follows (Refer to General Safety Information section for metric conversions).

▲ CAUTION Never overfire the unit heater, as this may cause unsatisfactory operation, or shorten the life of the heater.

1. Turn off all gas appliances that use gas through the same meter as the unit heater.
2. Turn the gas on to the unit heater.
3. Clock the time in seconds required to burn 1 cubic foot of gas by checking the gas meter.
4. Insert the time required to burn one cubic foot of gas into the following formula and compute the input rate.

$$\frac{3600 \text{ (Sec. per Hr.)} \times \text{BTU/Cu. Ft.}}{\text{Time (Sec.)}} = \text{Input Rate}$$

For example:

Assume the BTU content of one cubic foot of gas is 1000, and that it takes 18 seconds to burn one cubic foot of gas.

$$\frac{3600 \times 1000}{18} = 200,000$$

NOTICE: If the computation exceeds, or is less than 95% of the gas BTU/hr. input rating (see Table 1), adjust the gas pressure.

Adjust the gas pressure as follows:

1. NATURAL GAS: Best results are obtained when the unit heater is operating at its full rated input with the manifold pressure of 3.5 in. W.C. (0.9 kPa). Adjustment of the pressure regulator is not normally necessary since it is preset at the factory. However, field adjustment may be made as follows:
 - a. Attach manometer at the pressure tap plug adjacent to the control outlet.
 - b. Remove the regulator adjustment screw cap, located on the combination gas valve.
 - c. With a small screwdriver, rotate the adjustment screw counterclockwise to decrease pressure, or clockwise to increase pressure.
 - d. Replace regulator adjustment screw cap.

2. PROPANE GAS: An exact manifold pressure of 10.0 in. W.C. (2.5 kPa) must be maintained for proper operation of the unit heater. If the unit is equipped with a pressure regulator on the combination gas valve, follow steps "a" through "d" above. If the unit is not so equipped, the propane gas supply system pressure must be regulated to attain this manifold operating pressure.
3. The adjusted manifold pressure should not vary more than 10% from pressure specified in Table 6.

Table 6 - Main Burner Orifice Schedule*

* INPUT IN 1000 BTU	TYPE OF GAS	NATURAL	PROPANE	NO. OF BURNER ORIFICES
	HEATING VALUE	1050 BTU/Ft ³ (39.1 MJ/m ³)	2500 BTU/Ft ³ (93.1 MJ/m ³)	
	MANIFOLD PRESSURE	3.5" W.C. (0.87kPa)	10" W.C. (2.49 kPa)	
100	FT ³ /HR	93	40	4
	ORIFICE DRILL	42	53	
125	FT ³ /HR	116	50	5
	ORIFICE DRILL	42	53	
150	FT ³ /HR	140	60	6
	ORIFICE DRILL	42	53	
175	FT ³ /HR	163	70	7
	ORIFICE DRILL	42	53	
200	FT ³ /HR	186	80	8
	ORIFICE DRILL	42	53	
250	FT ³ /HR	233	100	9
	ORIFICE DRILL	42	53	
300	FT ³ /HR	280	120	10
	ORIFICE DRILL	42	53	
350	FT ³ /HR	326	140	11
	ORIFICE DRILL	42	53	
400	FT ³ /HR	372	160	12
	ORIFICE DRILL	42	53	

*This schedule is for units at operating at normal altitudes of 2000 ft. (610m) or less.

When installed in Canada, any references to deration at altitudes in excess of 2000 ft. (610m) are to be ignored. At altitudes of 2000 to 4500 ft. (610 to 1372m), the unit heaters must be field derated to 90% of the normal altitude rating, and be so marked in accordance with ETL certification. See Table 6A for field deration information.

OPERATION (continued)

Table 6A

TUBULAR UNIT HEATER HIGH ALTITUDE DERATION

This Tubular Unit Heater has been manufactured utilizing standard burner orifices and a normal manifold pressure setting as per the specifications shown on your unit rating plate.

All unit deration must be done through field adjustments by a qualified technician. Once the proper adjustments are made in the field, attach label #J17-06459 to the unit, and record adjusted manifold pressure, altitude of the unit installation and the technician's name and date on the label using a permanent marker.

Refer to Installation Instruction section on Adjustments-Gas Input Rate for adjusting the manifold pressure.

Altitude (Feet)	NATURAL GAS		PROPANE (LP) GAS	
	Heating* Value BTU/Hr.	Manifold* Pressure (In. W.C.)	Heating* Value BTU/Hr.	Manifold* Pressure (In. W.C.)
2,000*	948	3.5	2,278	8.6
2,500*	931	3.5	2,237	8.5
3,000*	914	3.3	2,196	8.4
3,500*	897	3.2	2,156	8.4
4,000*	881	3.2	2,116	8.3
4,500*	865	3.2	2,077	8.2
5,000	849	3.1	2,039	8.1
5,500	833	3.1	2,000	8.0
6,000	818	3.0	1,964	7.9
6,500	802	3.0	1,927	7.7
7,000	787	2.9	1,891	7.6
7,500	771	2.9	1,853	7.5
8,000	756	2.8	1,817	7.4
8,500	741	2.8	1,781	7.2
9,000	726	2.7	1,745	7.1
9,500	711	2.7	1,709	6.9
10,000	696	2.6	1,673	6.8

*Notes:

1. Consult local utility for actual heating value.
2. Tables based on Natural Gas heating value of 1,050 BTU/Hr. at sea level and Propane (LP) Gas heating value of 2,500 BTU/Hr. at sea level.
3. For installations in Canada at altitudes of 2,000-4,500 ft.: adjust the manifold pressure to 2.8 in. W.C. for Natural Gas and 8.1 in. W.C. for Propane (LP) Gas.

Table 7 - Separated Combustion Tubular Propeller Troubleshooting Guide

SYMPTOMS	POSSIBLE CAUSE(S)	CORRECTIVE ACTION
A. Flame pops back.	1. Burner orifice too small.	1. Check with local gas supplier for proper orifice size and replace. Refer to "Operation".
B. Noisy Flame.	1. Irregular orifice causing whistle or resonance. 2. Excessive gas input.	1. Replace orifice. 2. Test and reset manifold pressure.
C. Yellow tip flame (some yellow tipping on LP gas is permissible).	1. Clogged main burners. 2. Misaligned orifices. 3. Insufficient combustion air. 4. Possibly over fired.	1. Clean main burner ports. 2. Replace manifold assembly. 3. Refer to "Installation" clearances and venting to ensure unit is properly mounted and vented. 4. Check gas input and manifold pressures.
D. Floating flame.	1. Blocked venting. 2. Insufficient combustion air. 3. Blocked heat exchanger. 4. Air leak into combustion chamber or draft hood.	1. Clean Flue. Refer to "Installation". 2. Clean combustion air inlet openings. 3. Clean heat exchanger. Refer to "Installation". 4. Determine cause and repair accordingly.
E. Gas odor.	1. Shut off gas supply immediately! 2. Leaking gas test port on valve. 3. Blocked heat exchanger. 4. Blocked draft hood. 5. Negative pressure in the building.	1. Inspect all gas piping and repair. 2. Check to ensure gas test ports are sealed. 3. Clean heat exchanger/flue. Refer to "Installation". 4. Clean flue collector. Refer to "Installation". 5. See "Installation".
F. Delayed ignition.	1. Improper ground. 2. Bad or broken spark cable. 3. Faulty control. 4. Pressure regulator set too low. 5. Main burner orifices dirty. 6. Improper venting.	1. Check grounding wires and spark bracket connections. 2. Inspect spark cable connections and cuts. Replace if necessary. 3. Check to ensure spark is energized after pre purge period. 4. Test and reset manifold pressure, refer to "Operation". 5. Clean or replace orifices. 6. Refer to "Installation".
G. Failure to ignite.	1. Gas leak. Shut off gas supply immediately! 2. No power supply to unit. 3. Thermostat not calling. 4. Defective high limit. 5. Defective drafter prove switch. 6. Loose wiring. 7. Improper ground. 8. Improper thermostat or transformer wiring.	1. Open all manual valves, check for leaks . 2. Turn on power supply, check fuses and replace if bad. 3. Turn up thermostat, Check for 24V on terminals R and W1 on terminal strip. 4. Check switch for continuity if open with no heat present, replace. 5. Check switch operation to ensure switch closes after drafter purge period. If it does not make, check tubing connections for blockage. 6. Check all wiring per diagram. 7. Check all ground wires and connections. 8. Check both, for wiring according to diagram; check for 24V at gas valve terminals during trial for ignition period if present and valve does not open. Replace valve.
H. Condensation.	1. Improper venting. 2. Unit under fired. 3. Building too cold.	1. Refer to "Installation, Venting". 2. Check gas supply pressures to unit. Refer to "Installation". 3. Refer to "Installation".

Table 7 - Separated Combustion Tubular Propeller Troubleshooting Guide (continued)

SYMPTOMS	POSSIBLE CAUSE(S)	CORRECTIVE ACTION
I. Burners will not shut off.	<ol style="list-style-type: none"> 1. Thermostat located incorrectly. 2. Improper thermostat wiring. 3. Shorted circuit. 4. Defective/sticking gas valve. 5. Excessive gas supply pressure. 6. Defective thermostat. 7. Defective control board. 	<ol style="list-style-type: none"> 1. Relocate thermostat away from outside wall or drafts. 2. Check thermostat circuit for open and close on terminal strip on heater "R" and "W". 3. Check thermostat circuit for shorts or staples piercing wires. 4. Check for 24V on gas valve terminals when thermostat is not calling. 5. Refer to "Installation". "Gas Piping Requirements". 6. If thermostat is calling after set point has been satisfied, replace. 7. Check for 24V at terminals "R" and "W". If not present and board is not in flash code mode, replace board.
J. Rapid burner cycling.	<ol style="list-style-type: none"> 1. Loose electrical connections at thermostat or gas valve. 2. Excessive thermostat heat anticipator setting. 3. Unit cycling on high limit. 4. Poor thermostat location. 	<ol style="list-style-type: none"> 1. Tighten all electrical connections. 2. Adjust heat anticipator setting for longer cycles. Refer to "Electrical Connections". 3. Check for proper air supply across heat exchanger and proper gas supply. 4. Relocate thermostat away from outside wall or drafts.
K. Noisy power ventor.	<ol style="list-style-type: none"> 1. Power ventor wheel loose. 2. Power ventor wheel is dirty. 3. Power ventor wheel is rubbing on the housing. 	<ol style="list-style-type: none"> 1. Replace or tighten. 2. Clean power ventor wheel. 3. Realign power ventor wheel.
L. Fan will not run.	<ol style="list-style-type: none"> 1. Loose electrical connections. 2. Defective motor or overload. 3. Defective control board. 	<ol style="list-style-type: none"> 1. Check and tighten wires on fan circuit. 2. Test for 115V on terminal ACB Heat and "L2". If voltage is present, replace motor. 3. Test for 115V on terminal ACB Heat and "L2" on the control board. If voltage is not present 45 seconds after trial for ignition, replace board.
M. Fan motor turns on and off while burner is operating.	<ol style="list-style-type: none"> 1. Motor overload protection is tripping. 2. Loose wiring or connection. 3. Control board is defective. 	<ol style="list-style-type: none"> 1. Check motor amps against motor name plate, check voltage, replace if found defective. 2. Check for 115V between motor leads. 3. Check terminal ACB Heat for voltage. If voltage not constant, replace board.
N. Fan will not stop.	<ol style="list-style-type: none"> 1. Control Board is in flame failure mode. 2. Fan improperly wired. 3. Defective board. 	<ol style="list-style-type: none"> 1. Turn 115V power off to the unit, wait 10 seconds and reapply voltage to the unit. 2. Check wiring of fan circuit to wiring diagram. 3. If unit is not calling for heat and board is not in a flash code mode, replace board.
O. Not enough heat.	<ol style="list-style-type: none"> 1. Incorrect gas input. 2. Heater undersized. 3. Thermostat malfunction. 4. Heater cycling on limit. 5. Incorrect orifice sizes. 	<ol style="list-style-type: none"> 1. Refer to "Operation". 2. Is the heater output sized correctly for heat loss of the space? Has the space been enlarged? 3. Check thermostat circuit, 24V on terminals "R" and "W" on terminal strip. 4. Check air movement across heat exchanger. Check voltage and amps at the fan motor. Check gas input to ensure unit is not over fired. Check heat exchanger to ensure unit is not dirty. 5. Check orifice size, replace if undersized.
P. Too much heat.	<ol style="list-style-type: none"> 1. Unit is over fired. 2. Thermostat malfunction. 3. Heater runs continuously. 	<ol style="list-style-type: none"> 1. Refer to "Operation". Check orifice size. If too big replace. 2. Check thermostat for operation, to ensure circuit open and closes. 3. Check wiring per diagram; check operation at the gas valve, look for a short in thermostat circuit.

Table 7 - Separated Combustion Tubular Propeller Troubleshooting Guide

SYMPTOMS	POSSIBLE CAUSE(S)	CORRECTIVE ACTION
Q. Cold air is delivered during heater operation.	<ol style="list-style-type: none"> 1. Incorrect manifold pressure or input. 2. Air throughput too high. 	<ol style="list-style-type: none"> 1. Refer to "Gas Piping Requirements", test and reset manifold pressure. 2. Refer to "Operation".
R. High limit tripping.	<ol style="list-style-type: none"> 1. Unit is over fired. 2. Air flow is low. 3. Defective switch. 4. Defective control board. 	<ol style="list-style-type: none"> 1. Burner orifices may be too large, verify and replace. Refer to "Gas Input Rate". 2. Check for proper voltage, ensure fan blade is correct. 3. Check operation of switch. If switch is open during operation, check gas pressure; adjust accordingly. If switch is open during start-up, replace switch. 4. Check for 24V on line side of the high limit. Constant voltage should be recorded. If not control board is suspect. Check flash code.
S. Power ventor will not run.	<ol style="list-style-type: none"> 1. Loose wiring or connections. 2. Motor overload is tripped or bad motor. 3. Defective control board. 	<ol style="list-style-type: none"> 1. Check all wiring in the power vent circuit to ensure good connection, including "Neutral". 2. Check for 115V between motor leads and check amp draw of motor. Replace if needed. 3. Check for continuous 115V on terminal "CBM Blower" and neutral during call for heat. If not present and all checks are normal, replace.
T. Power ventor turns on and off during operation.	<ol style="list-style-type: none"> 1. Power ventor improperly wired. 2. Motor overload cycling or defective motor. 3. Defective control board. 	<ol style="list-style-type: none"> 1. Check power ventor circuit per wiring diagram. 2. Check motor voltage and amp draw to motor name plate, replace if motor found defective. 3. Check for continuous 115V on terminal "CMB Blower" during call for heat, replace board if found defective.
U. Power ventor will not stop.	<ol style="list-style-type: none"> 1. Power ventor improperly wired. 2. Main burner did not light on call for heat. 3. Defective control board. 	<ol style="list-style-type: none"> 1. Check power ventor circuit per wiring diagram. 2. Heater is in lockout mode check flash code table for problem. 3. No flash codes present along with no call for heat, replace control board.

Table 8 - Separated Combustion Tubular Propeller Troubleshooting with LED Indicator Assistance

No Cycling or appliance power or thermostat call for heat since appliance failure has occurred.

▲ WARNING

Line voltage power can cause product damage, severe injury or death. Only a trained experienced service technician should perform this troubleshooting.

1. Check the system thermostat to make sure it is calling for heat. (Do not cycle the thermostat on and off at this time.)
2. Do not interrupt power to the control board by opening any electrically interlocked panels.
3. Observe the LED indicator on the bottom of the electrical compartment (a green LED indicates system faults); check and repair system as noted in the chart to the right.

***NOTICE: Air flow proving switch and power ventor hose barbs must be free of any dust or debris at all times. Periodically check these openings and/or if any problems occur.**

LED STATUS	INDICATES	CHECK/REPAIR
Slow Flash	Control OK, no call for heat.	Not Applicable
Fast Flash	Control OK, call for heat present.	Not Applicable
Steady Off	Internal control fault, or no power.	<ol style="list-style-type: none"> 1. Line voltage on terminals 120 and C on transformer. 2. Low voltage (24V) on terminals 24 and C on transformer. 3. 5 Amp fuse on circuit board.
Steady On	Control internal failure or bad ground.	<ol style="list-style-type: none"> 1. Common side of transformer grounded to chassis. 2. Loose spark ignitor.
2 Flashes	In lockout from failed ignitions or flame losses.	<ol style="list-style-type: none"> 1. Gas supply off or gas supply pressure too low. 2. Flame sense rod contaminated or loose wire. 3. Gas valve switch is off or wires are not connected. 4. Broken or cracked porcelain on flame probe or spark ignitor.
3 Flashes	Pressure Switch open with inducer on or closed with inducer off.	<ol style="list-style-type: none"> 1. Obstructions or restrictions in appliance air intake or flue outlet are preventing proper combustion airflow. 2. Moisture or debris in tubing that connects pressure switch and draft inducer. 3. Airflow switch jumpered or miswired.
4 Flashes	Limit or rollout switch is open.	<ol style="list-style-type: none"> 1. Open manual reset rollout switch. 2. Gas pressure too high, over fire condition. 3. Incorrect airflow due to blockage or motor not operating.
5 Flashes	Flame sensed while gas valve is off.	<ol style="list-style-type: none"> 1. Flame probe miswired or shortened.
6 Flashes	On-board microprocessors disagree.	<ol style="list-style-type: none"> 1. Thermostat is interfering with control board.

MAINTENANCE

PERIODIC SERVICE

NOTICE: The heater and vent system should be checked once a year by a qualified technician.

All Maintenance/Service information should be recorded accordingly on the Inspection Sheet provided in this manual.

▲ WARNING Open all disconnect switches and disconnect all electrical and gas supplies and secure in that position before servicing unit. Failure to do so may result in personal injury or death from electrical shock.

▲ WARNING Gas tightness of the safety shut-off valves must be checked on at least an annual basis. Failure to do so may result in death, serious injury or substantial property damage.

To check gas tightness of the safety shut-off valves, turn off the manual valve upstream of the appliance combination control. Remove the 1/8 in. pipe plug on the inlet side of the combination control and connect a manometer to that tapping. Turn the manual valve on to apply pressure to the combination control. Note the pressure reading on the manometer, then turn the valve off. A loss of pressure indicates a leak. If a leak is detected, use a soap solution to check all threaded connections. If no leak is found, combination control is faulty and must be replaced before putting appliance back in service.

Should maintenance be required, perform the following inspection and service routine:

1. Inspect the area near the unit to be sure that there is no combustible material located within the minimum clearance requirements listed in this manual.

▲ WARNING Under no circumstances should combustible material be located within the clearances specified in this manual. Failure to provide proper clearance could result in personal injury or equipment damage from fire.

2. Turn off the manual gas valve and electrical power to the unit heater.
3. To clean or replace the burners, remove combustion air inlet piping from the unit, remove screws from access cover and swing access cover down. Remove top strip from above burners by removing sheet metal screws. Lift burners up and pull away from manifold to remove.
4. With the burners removed, wire brush the inside surfaces of the heat exchanger.
5. Remove any dirt, dust, or other foreign matter from the burners using a wire brush and/or compressed air.
6. Inspect air inlet for blockage/debris. Clear if any found.
7. Reassemble the unit heater by replacing all parts in reverse order.
8. Check the burner adjustment.
9. Check all gas control valves and pipe connections for leaks.
10. Check the operation of the automatic gas valve by lowering the setting of the thermostat, stopping the operation of the gas duct furnace. The gas valve should close tightly, completely extinguishing the flame on the burners.
11. Inspect and service motor/fan assembly. To maintain efficient air flow, inspect and clean the fan blades and guard to prevent buildup of foreign matter.
12. Check motor lubrication. If oiling is required, add 1 or 2 drops of electric motor oil as follows:
 - a. Light Duty - After 3 years or 25,000 hours of operation.
 - b. Average Duty - Annually after 3 years or 8,000 hours of operation.
 - c. Heavy Duty - Annually after 1 year or at least 1500 hours of operation.

▲ CAUTION Never over oil the motor or premature failure may occur! Over oiling the motor may result in minor injury or property damage.

13. Check and test the operational functions of all safety devices supplied with your unit.

LIMITED WARRANTY

Separated Combustion Tubular Propeller Unit Heaters

1. The "Manufacturer" warrants to the original owner at original installation site that the above model Gas-Fired Heater ("the Product") will be free from defects in material or workmanship for (1) year from the date of shipment from the factory, or one and one-half (1-1/2) years from the date of manufacture, whichever occurs first. The Manufacturer further warrants that the complete heat exchanger, flue collector, and burners be free from defects in material or workmanship for a period of ten (10) years from the date of manufacture. If upon examination by the Manufacturer the Product is shown to have a defect in material or workmanship during the warranty period, the manufacturer will repair or replace, at its option, that part of the Product which is shown to be defective.
2. This limited warranty does not apply:
 - a. if the product has been subjected to misuse or neglect, has been accidentally or intentionally damaged, has not been installed, maintained, or operated in accordance with furnished written instructions, or has been altered or modified in any way by any unauthorized person.
 - b. to any expenses, including labor or material, incurred during removal or reinstallation of the Product
 - c. to any damage due to corrosion by chemicals, including halogenated hydrocarbons, precipitated in the air
 - d. to any workmanship of the installer of the Product
3. This limited warranty is conditional upon:
 - a. advising the installing contractor, who in turn notify the distributor or manufacturer
 - b. shipment to the Manufacturer of that part of the Product thought to be defective. Goods can only be returned with prior written approval of the Manufacturer. All returns must be freight prepaid.
 - c. determination in the reasonable opinion of the Manufacturer that there exists a defect in material or workmanship
4. Repair or replacement of any part under this Limited Warranty shall not extend the duration of the warranty with respect to such repaired or replaced part beyond the stated warranty period.
5. **THIS LIMITED WARRANTY IS IN LIEU OF ALL WARRANTIES, EITHER EXPRESS OR IMPLIED, AND ALL SUCH OTHER WARRANTIES, INCLUDING WITHOUT LIMITATION IMPLIED WARRANTIES OF MERCHANTABILITY OR FITNESS FOR A PARTICULAR PURPOSE, ARE HEREBY DISCLAIMED AND EXCLUDED FROM THIS LIMITED WARRANTY. IN NO EVENT SHALL THE MANUFACTURER BE LIABLE IN ANY WAY FOR ANY CONSEQUENTIAL, SPECIAL, OR INCIDENTAL DAMAGES OF ANY NATURE WHATSOEVER, OR FOR ANY AMOUNTS IN EXCESS OF THE SELLING PRICE OF THE PRODUCT OR ANY PARTS THEREOF FOUND TO BE DEFECTIVE. THIS LIMITED WARRANTY GIVES THE ORIGINAL OWNER OF THE PRODUCT SPECIFIC LEGAL RIGHTS. YOU MAY ALSO HAVE OTHER RIGHTS WHICH MAY VARY BY JURISDICTION.**

In the interest of product improvement, we reserve the right to make changes without notice.

IDENTIFICATION OF PARTS PROPELLER UNIT HEATERS

Figure 10 - Propeller Parts

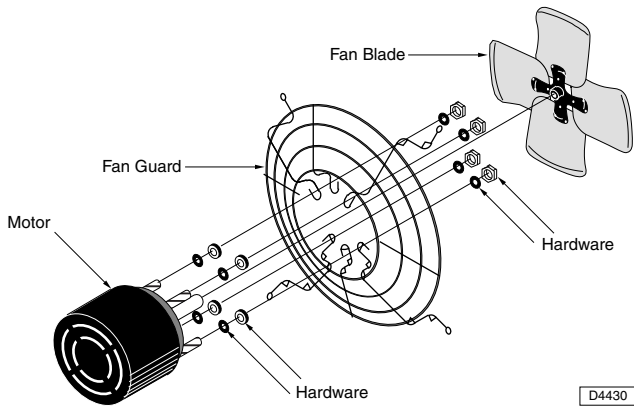

D4430

Figure 11 - Component Parts

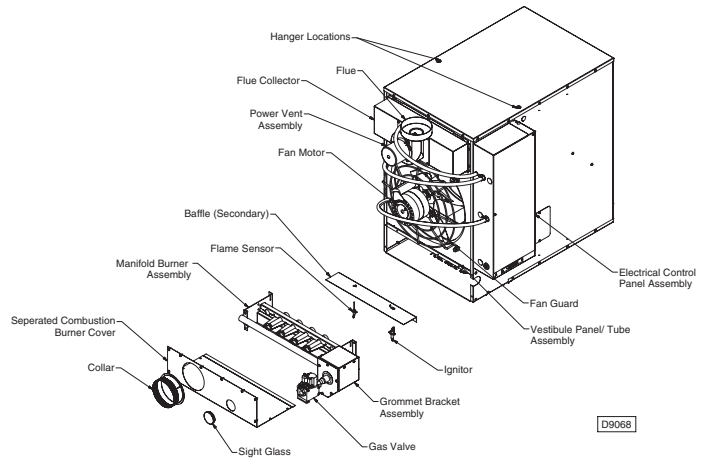

D9068

Figure 12 - Heat Exchanger Assembly

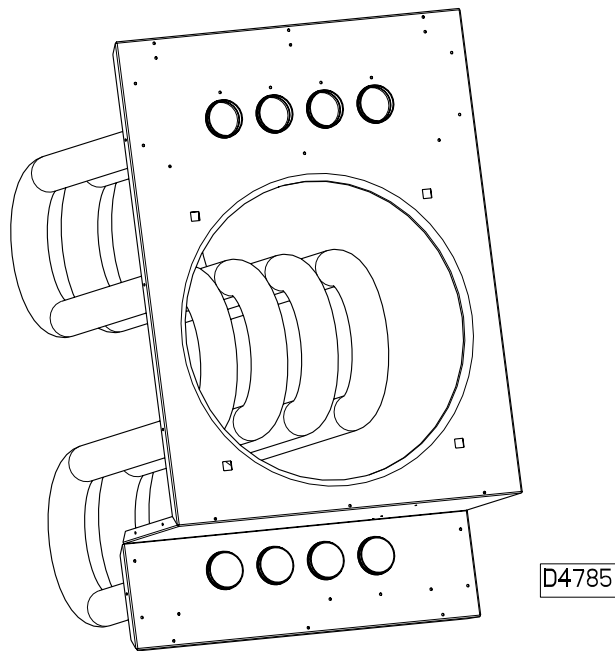

D4785

Figure 13 - Electrical Control Panel

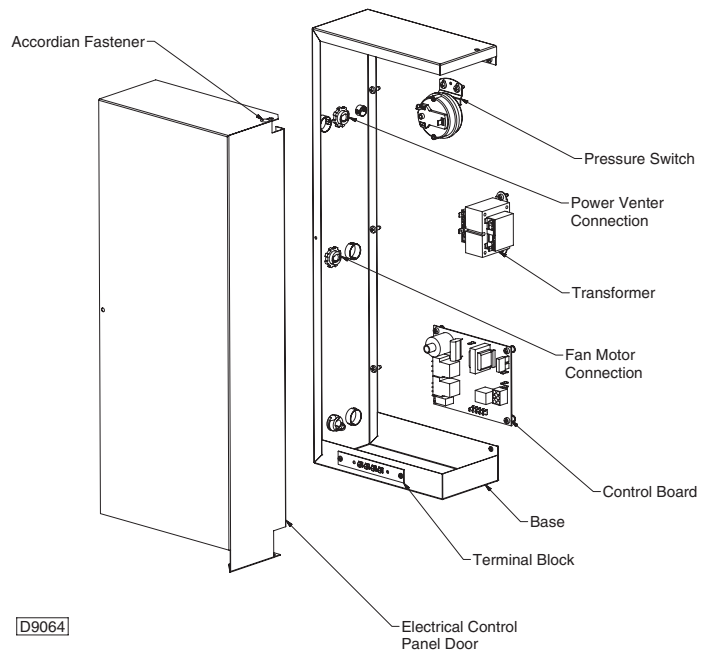

D9064

**Figure 14 - Power Venter Assembly
(150/250 Unit Sizes Shown)**

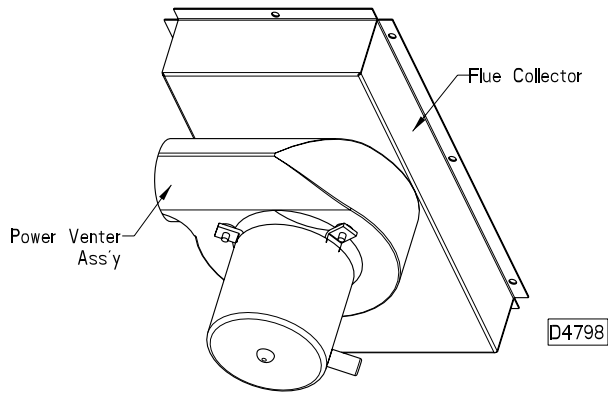

**Figure 15 - Power Venter Assembly
(300/400 Unit Sizes Shown)**

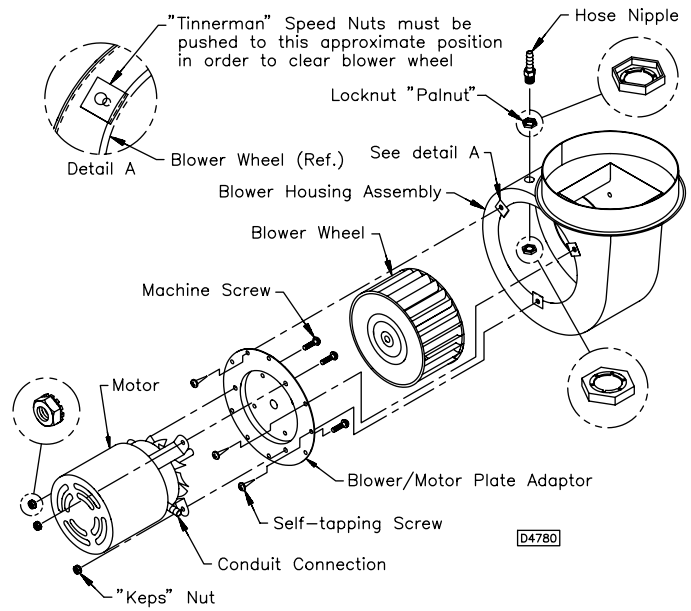
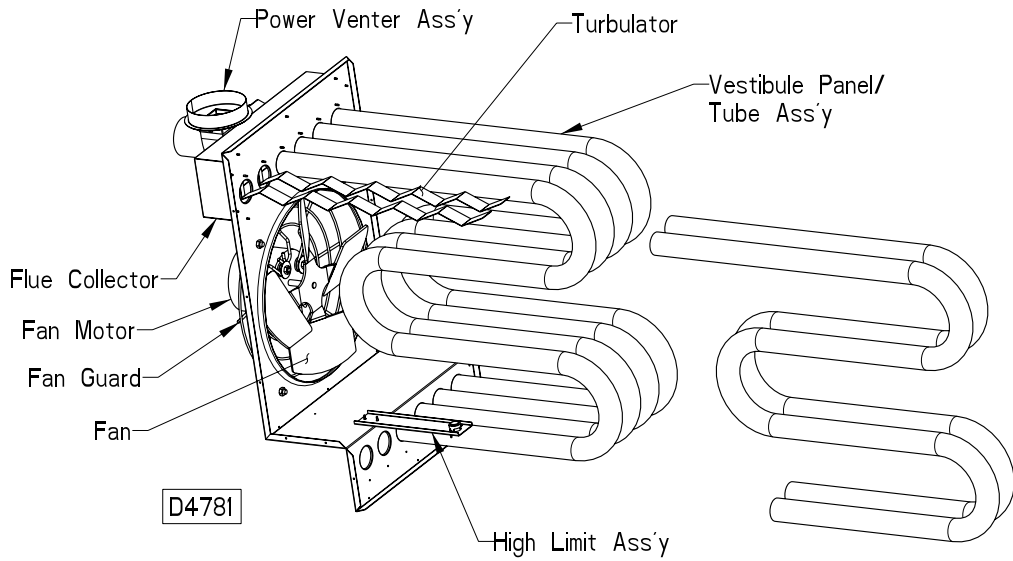

Figure 16 - Turbulator/High Limit Location



HOW TO ORDER REPLACEMENT PARTS

Please send the following information to your local representative: if further assistance is needed, contact the manufacturer's customer service department.

- Unit Number
- Serial Number
- Part Description and Number as shown in Replacement parts Catalog

NOTES:

SEPARATED COMBUSTION TUBULAR PROPELLER UNIT NUMBER DESCRIPTION

DIGIT	T	X	X	X	-	1	2	3	4	5	6	7	8	9	10	11	12	13	14	+
ITEM	PREFIX					UT		CA			FT	FM	GT	AL	GC	SV	MT	MS	AS	

(Internal Use Only)

Digit #1, 2 - Unit Type [UT]

SF - Separated Combustion Tubular Propeller

Digit #3, 4, 5 - Capacity [CA]

- 100 - 100,000 BTU/HR
- 125 - 125,000 BTU/HR
- 150 - 150,000 BTU/HR
- 175 - 175,000 BTU/HR
- 200 - 200,000 BTU/HR
- 250 - 250,000 BTU/HR
- 300 - 300,000 BTU/HR
- 350 - 350,000 BTU/HR
- 400 - 400,000 BTU/HR

Digit #6 - Furnace Type [FT]

A - Right Side Access

Digit #7 - Heat Exchanger Construction Material [FM]

- 1 - Standard (Aluminized) Steel
- 2 - 409 Stainless Steel

Digit #8 - Gas Type [GT]

- N - Natural Gas
- P - Propane Gas (LP)

Digit #9 - Altitude [AL]

- S - 0-4,999 ft.
- T - 5,000-11,999 ft.

Note: Installations over 2,000 ft. require gas input deration in the field. Refer to unit installation instructions.

Digit #10 - Direct Spark Gas Control [GC]

- 1 - Single Stage
- 2 - Two Stage
- 3 - Electronic Modulation w/Room Sensing
- 6 - Electronic Modulation w/External 4-20 mA Input
- 7 - Electronic Modulation w/External 0-10 VDC Input

Digit #11 - Supply Voltage [SV]

- 1 - 115/1/60 5 - 230/3/60
- 2 - 208/1/60 6 - 460/3/60
- 3 - 230/1/60 7 - 575/3/60
- 4 - 208/3/60 Z - Special

Note: Supply Voltages [SV] 2-7 include field mounted step down transformer.

Digit #12 - Motor Type [MT]

- 1 - Open Drip Proof (Standard)
- 2 - Totally Enclosed

Digit #13 - Blower Motor Sizes [MS]*

0 - None/Not Applicable

*Note: Blower Motor Size [MS] not applicable for propeller type unit heaters.

Digit #14 - Accessories [AS]

FACTORY INSTALLED

- M6 - OSHA Type Fan Guard
- P4 - Terminal Block Wiring
- P6 - Summer/Winter Switch
- S3 - 409 Stainless Steel Flue Collector
- S5 - 304L Stainless Steel Burners

† FIELD INSTALLED (AS-____)

All Field Installed Accessories are to be entered as a separate line item using catalog number which utilizes "AS" as a prefi x. i.e: A7 becomes AS-A7.

- A7 - Pressure Regulator 1/2-2 psi
- P5 - 24V SPST Relay-Specify Purpose

G1 - 1-Stage T87K Mercury Free Thermostat w/Subbase Kit

X2 - 30 Degree Downturn Nozzle

G2 - 1-Stage T87K Mercury Free Thermostat w/TG511A Guard Kit

X3 - 60 Degree Downturn Nozzle

G3 - 1-Stage T834N Mercury Free Thermostat/Fan Switch

X4 - 90 Degree Downturn Nozzle

G5 - 2-Stage TH5220D Mercury Free Thermostat w/Subbase

X5 - Vertical Louver Kit

G6 - Locking Thermostat Cover

X7-H5 - Horiz. Combustion Air Inlet Kit, 5 inch (Unit Capacity 100-250)

G9 - 1-Stage T822K Mercury Free Thermostat

X7-H6 - Horiz. Combustion Air Inlet Kit, 6 inch (Unit Capacity 300-400)

M2-2 - Vent Caps (5") (Unit Capacity 100-250)

X7-V5 - Vert. Combustion Air Inlet Kit, 5 inch (Unit Capacity 100-250)

M2-3 - Vent Caps (6") (Unit Capacity 300-400)

X7-V6 - Vert. Combustion Air Inlet Kit, 6 inch (Unit Capacity 300-400)

GAS EQUIPMENT START-UP

Customer _____ Job Name & Number _____

PRE-INSPECTION INFORMATION With power and gas off.

Type of Equip: Unit Heater

Serial Number _____ Model Number _____

Name Plate Voltage: _____ Name Plate Amperage: _____

Type of Gas: Natural LP Tank Capacity _____ lbs. Rating: _____ BTU @ _____ °F
_____ kg _____ kw @ _____ °C

- Are all panels, doors, vent caps in place?
- Has the unit suffered any external damage? Damage _____
- Does the gas piping and electric wiring appear to be installed in a professional manner?
- Has the gas and electric been inspected by the local authority having jurisdiction?
- Is the gas supply properly sized for the equipment?
- Were the installation instructions followed when the equipment was installed?
- Have all field installed controls been installed?
- Do you understand all the controls on this equipment? ***If not, contact your wholesaler or rep. (DO NOT START this equipment unless you fully understand the controls.)***

GENERAL

With power and gas off.

- Make certain all packing has been removed.
- Tighten all electrical terminals and connections.
- Check damper linkages for tightness.
- Check all fans & blowers for free movement.
- Check all controls for proper settings.

FAN

With power and gas off.

- Check voltage L1___ L2___ L3___
- Check rotation of main propellor(s).
- Check motor amps L1___ L2___ L3___

GAS HEATING

With power and gas on.

- Inlet gas pressure. _____ in. W.C. or _____ kPa
- Burner ignition.
- Manifold gas pressure. _____ in. W.C. or _____ kPa
- Cycle firestat and/or freezestat.
- Check electronic modulation. Set at: _____
- Cycle and check all other controls not listed.
- Check operation of remote panel.
- Entering air temp. _____ °F or _____ °C
- Discharge air temp. (high fire) _____ °F. or _____ °C
- External static pressure _____ in. W.C.
- Cycle by thermostat or operating control.
- Combustion Reading:
Carbon Monoxide: _____ PPM
Carbon Dioxide: _____ %

Remarks: _____



MESTEK, INC.

260 NORTH ELM ST., WESTFIELD, MA 01085
TEL: (413) 568-9571 FAX: (413) 562-5311
www.mestek.com

